

Old Rayne Friday 28th Sept 8pm - 11pm

1 THE KELLOHOLM JIG J32 · 3/4L

Peter Hyssett: *The Leaflet Dances with Music* · Crib: *MiniCrib*s · Diagram: Keith Rose's Diagrams

- 1-8 1s set & cast 1 place, set on side lines to 1st corners & change places with them RH
- 9-16 1L+3L also 2M+1M set to each other on sides & change places LH, 1s turn RH 1.1/2 times to 2nd place on own sides
- 17-24 1s set on side lines to 2nd corners & change places with them RH, 1M+3M also 2L+1L set to each other on sides & change places LH
- 25-32 3s+1s+2s Adv+Ret, circle 6H round 1/2 way to left

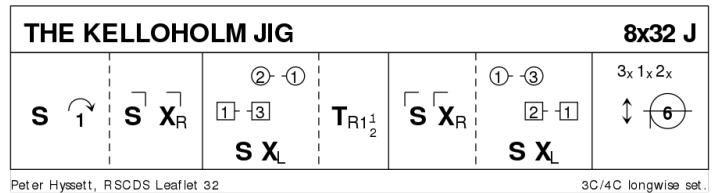

2 SCOTT MEIKLE R32 · 4/4L

Alice McLean: *RSCDS XLVI 3* · Crib: *MiniCrib*s · Diagram: Keith Rose's Diagrams

- 1-8 1s cross RH & cast to 2nd place, 1s dance 1/2 Fig of 8 round 2s
- 9-16 1s+3s dance RH across, LH back
- 17-24 1L followed by 3L dance Tandem reel of 3 across with 2s (LSh to 2M) & 1s end 3rd pl **while** 3M followed by 1M dance reel of 3 with 4s (LSh to 4L) & 3s end in 2nd pl 2 3 1 4
- 25-32 1s+4s dance 1/2 R&L, turn partners RH 1.1/2 times 2 3 4 1

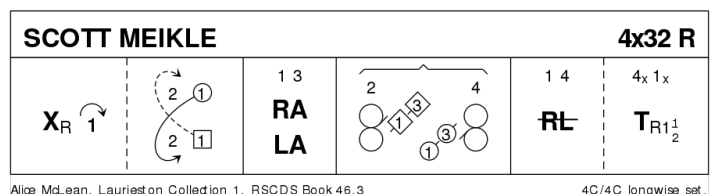

3 MATHILDE IS A DELIGHT S32 · 3/3L

Raphaëlle Orgeret: *RSCDS L 6* · Crib: *MiniCrib*s · Diagram: Keith Rose's Diagrams

- 1-8 1s+2s+3s dance Grand Chain
- 9-16 1L followed by 1M casts to 2nd place opp sides (2s step up). 1M followed by 1L casts to 3rd place own side (3s step up)
- 17-24 2s+3s+1s set, turn partners 1/2 RH, pull back RSh & dance out to opp sides. All set
- 25-26 2s+3s+1s circle 6H 1/2 round to Left .
1 3 2
- 27-32 1s+2s dance 'The Capstan'
- 27-28 1s NHJ dance down 2 places **while** 2s cast up to 1st place
- 29-30 2s NHJ dance down 2 places **while** 1s cast up to 1st place
- 31-32 1s NHJ dance down 2 places curving into 3rd place **while** 2s cast up to first place

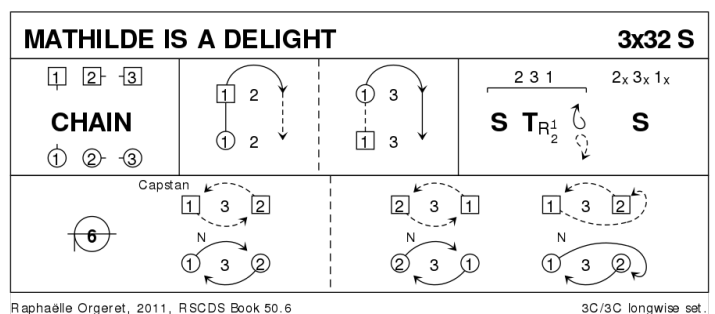

4 MIDNIGHT OIL J48 · 5/5L

John Drewry: Bankhead Book Part 3 · Crib: MiniCribs · Diagram: Keith Rose's Diagrams

- 1-8** 1s & 3s lead down & 3/4 turn RH to L facing down & M up, retaining hold of RH set & L turns under ptrns Rt arm to dance up (Men follow ptrnr)
- 9-16** 1s & 3s dance RH across with 2L/4L, 1s & 3s dance LH across with 4M/5M to end facing 1st corners
- 17-24** 1s also 3s dance Pass+Turn with 1st corners & pass RSh to face 2nd corners, dance Pass+Turn with 2nd corners & into centre facing partner (L facing down M up)
- 25-32** 1s+3s dance reel of 4 up & down centre of dance & end in centre holding partners nearer hand (1s face Ladies side & 3s face Men's side)
- 33-40** 1s also 3s dance out sides & cast, dance in to meet ptrnr (1M & 3L pass LSh) to dance out other side & cast back to middle (1M & 3L pass RSh & face each other)
- 41-48** 1L also 3M set twice **while** 1M+3L turn RH, 1s & 3s turn partner LH & cast down 1 place on own sides. End 2 4 1 5 3

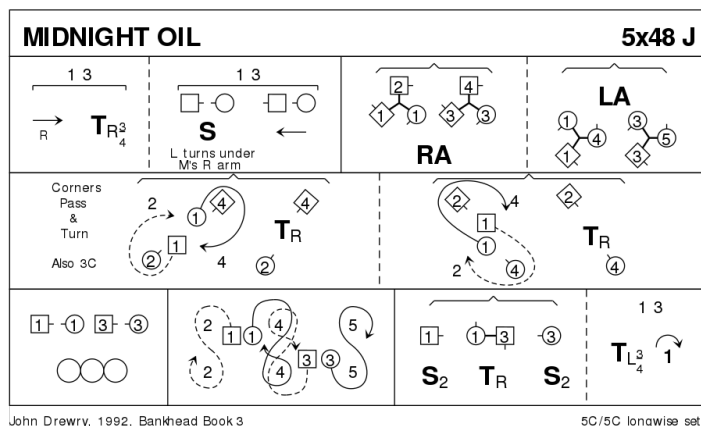

5 THE FIREWORKS REEL R32 · 3/4L

Anselm Lingnau: RSCDS XLVIII 11 · Crib: MiniCribs · Diagram: Keith Rose's Diagrams

- 1-8** 1s cross RH & cast 1 place, 1s dance 1/2 figures of 8 (1L round 2s, 1M round 3s) & end facing 1st corners
- 9-12** 1s set moving out between corners (as in Hello-Goodbye setting) & 1s turn LH to face 1st corners
- 13-16** 1s dance 1/2 diagonal reel of 4 with 1st corners & end facing 2nd corners
- 17-24** 1s repeat bars 9-16 with 2nd corners & end 2nd place opposite sides (3)(1)(2)
- 25-32** 1s dance 1/2 reel of 3 on opposite sides (1M in & down, 1L in & up), 1s dance 1/2 reel of 3 across (1M with 2s & 1L with 3s)

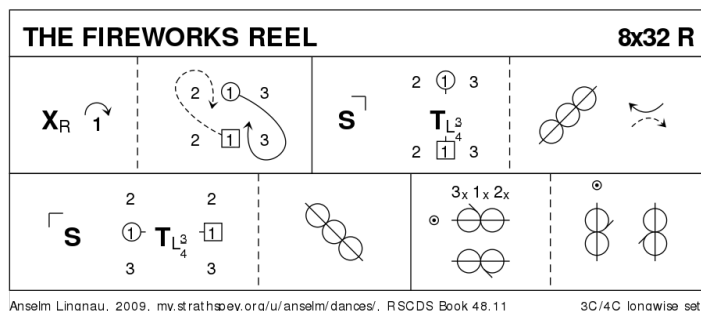

6 THE MORAY RANT S48 · 3/3L

John Drewry: Silver City Book of SCD · Crib: MiniCribs · Diagram: Keith Rose's Diagrams

- 1-8** 1s dance Inveran Reels with 2s+3s & 1s cross RH to opposite sides
- 9-16** 1s set advancing & turn 2H, dance down & out between 2s & 3s then cast down behind 3s to turn in to face 3s
- 17-24** 1s set & turn 3s (1s dancing out between 2s & 3s), dance up between 3s & out between 2s+3s then cast up behind 2s to turn in to face 2s
- 25-32** 1s set & turn 2s (1s dancing out between 2s & 3s) into 1st place opp sides, 1s dance 1/2 Fig of 8 round 2s back to 1st place own sides
- 33-40** 1s+2s circle 4H once round to Left, 1s facing 2s set & 1s cast to 2nd place as 2s lead up to 1st place
- 41-48** 1s+3s circle 4H once round to Left, 1s facing 3s set & 1s cast to 3rd place as 3s lead up to 2nd place

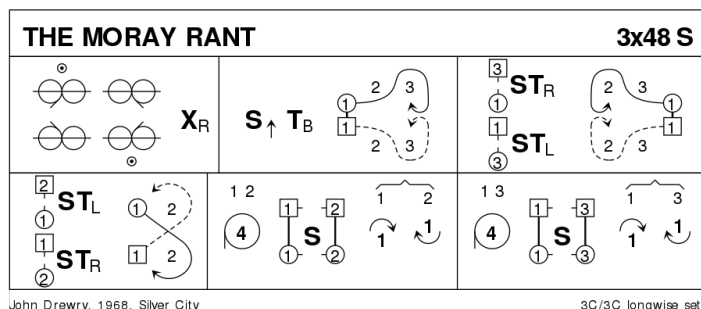

7 IAN POWRIE'S FAREWELL TO AUCHTERARDER J128 · 4S

Bill Hamilton: 90 - Twelve anniversary dances celebrating ninety years of RSCDS Edinburgh Branch 13 · Crib: MiniCribs · Diagram: Keith Rose's Diagrams

- 1-8** All circle 8H round to the left & back (popular variation - 8 hands all the way round to left)
- 9-24** Ladies dance in front of ptrn & behind next Man, into RH across, in front of Man opp own ptrn & behind next Man, into RH across & back to place
- 25-32** All Promenade clockwise
- 33-40** 1s & 3s dance cl'wise behind next couple & Men dance past cpl as Ladies dance in between cpl & both turn R to face cpl, all set & turn RH
- 41-48** All dance parallel reels of 4
- 49-56** 1s & 3s dance a full Fig of 8 round the standing 2s/4s
- 57-64** 1s & 3s dance LH across, 1s & 3s dance back to places (Men round & Ladies through the standing 2s & 4s)
- 65-96** 2s & 4s repeat 33-64
- 97-104** All Promenade anticlockwise
- 105-120** Men dance in front of ptrn & behind next Lady, into LH across, dance in front of Lady opp own partner & behind next L into LH across & back to pl
- 121-128** All circle 8H round to the right & back (popular variation - 8 hands all the way round to right)

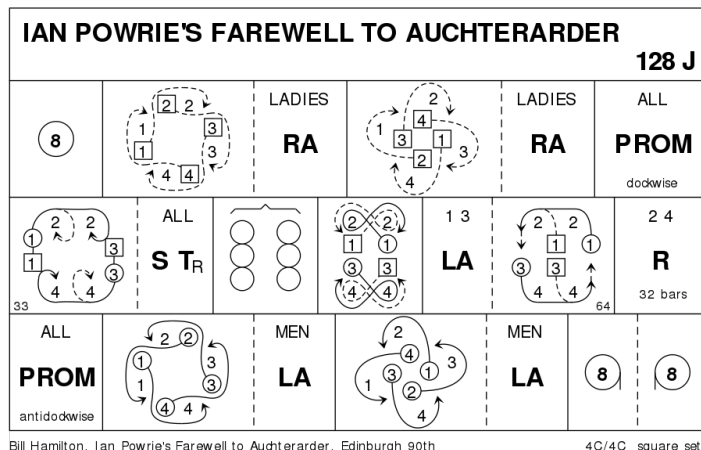

8 THE FALLS OF ROGIE R32 · 3/4L

Jean Attwood: Alexander Dances Book 1 · Crib: MiniCribS · Diagram: Keith Rose's Diagrams

- 1-8** 1s cross RH & cast 1 place, 1s cross RH & cast 1 place (Man up Lady down)
- 9-16** 1s dance 1/2 reels of 3 across (1M with 2s & 1L with 3s), set in lines across & change places RH with opposite person
- 17-24** 2s+1s+3s chase cl'wise 1/2 way, 1s dance in & turn RH to face 1st crnr pstns as 2s & 3s continue to chase on to places (as bar 16)
- 25-32** 1s dance 1/2 reel of 4 with 1st corners, passing RSh dance 1/2 reel with 2nd corners & cross passing RSh to 2nd place own sides

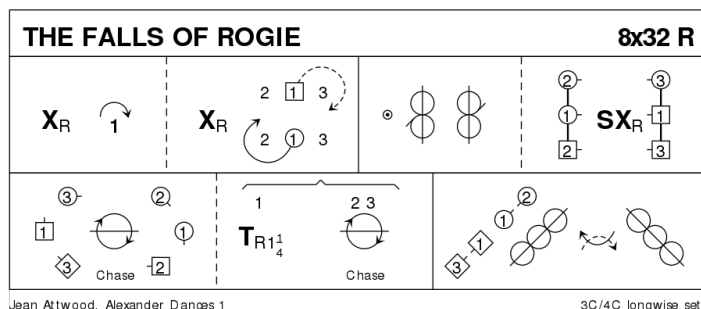

9 ROUGEMONT CASTLE S32 · 3/3L

Duncan Brown: RSCDS XLVIII 12 · Crib: MiniCribS · Diagram: Keith Rose's Diagrams

- 1-8** 1s lead down to bottom & cross to cast up to 2nd pl on opp sides, 1s dance 1/2 Fig of 8 (L up round 2s, M down). 2 1 3
- 9-16** All cross RH & chase clwise 1/4 way into lines across, all change places with partner RH & chase clwise to opp sides. (3)(1)(2)
- 17-24** 1s change places RH with person diagonally to right & new centre couple LH with person diag left, new centre cpl RH diag right & 2s (at top) cross RH as 1s & 3s 1/2 turn RH into Allemande hold
- 25-32** 1s+3s dance Allemande. 2 3 1

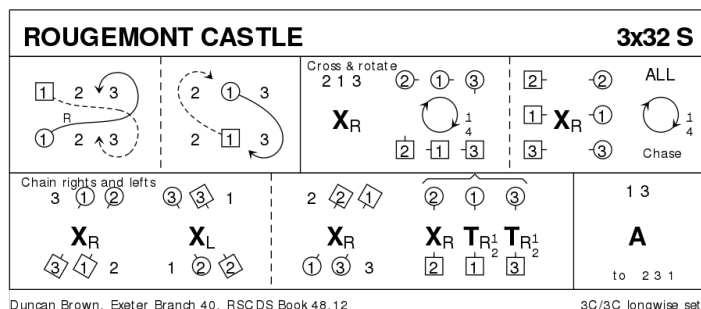

10 INCHMICKERY J32 · 5/5L

Roy Goldring: 14 Social Dances for 2000 · Crib: MiniCribS · Diagram: Keith Rose's Diagrams

- 1-8** 1s+2s circle 4H round to left, 1s dance in & cast to 3rd place
- 9-16** 1s dance RH across (1L with 3s & 1M with 4s), pass RSh & dance LH across with other couple 2 3 1 4 5
- 17-24** 1L+2M (at top) also 1M+5L (at bottom) turn RH, 1L+5M (at bottom) also 1M+2L (at top) turn LH (1s end 3rd place own side)
- 25-32** 1s dance in & cast to 5th place, 5s+1s circle 4H round to right. 2 3 4 5 1

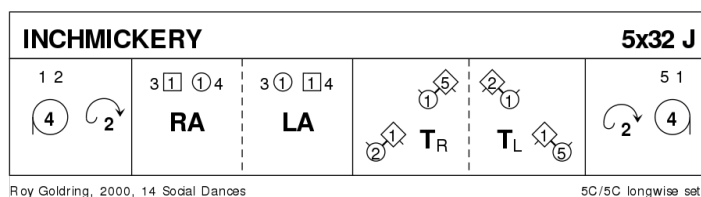

11 LOTHIAN LADS R32 · 3/4L

John Drewry: Summer Collection, Set 7 · Crib: MiniCribs · Diagram: Keith Rose's Diagrams

- 1-8** 1s lead down & 3/4 turn RH to 1L facing down, 1M up, set, retain hold of RH & 1L turns under ptrns right arm, 1L followed by 1M dance up
- 9-16** 1s dance RH across with 2L, 1s dance LH across with 3M to end facing 1st corners
- 17-24** 1s dance 1/2 reel of 4 with 1st corners, pass RSh to face 2nd corners. 1s dance 1/2 reel with 2nd corners, end in 2nd place opp side facing down
- 25-32** 3s+1s+2s dance 1/2 Grand Chain turning 3rd person RH to end 2 1 3

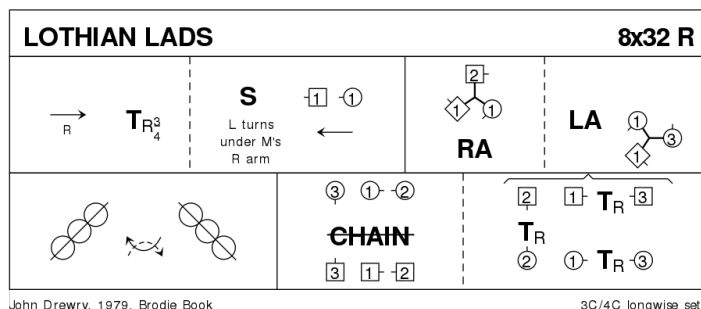

12 GOOD HEARTED GLASGOW J32 · 3/4L

Peter Knapman: Collins Pocket Reference: Scottish Country Dancing · Crib: MiniCribs · Diagram: Keith Rose's Diagrams

- 1-8** 1s turn RH & cast to 2nd place, turn partner LH 1.1/4 times to end Man facing down & Lady facing up
- 9-16** 1s dance RH across (Lady with 2s & Man with 3s), 1s pass RSh & dance LH across with other couple
- 17-24** 1s lead down the middle & back to 2nd place own side
- 25-32** 2s+1s+3s circle 6H round & back

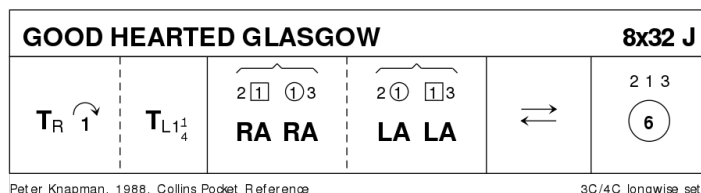

13 THE BYRON STRATHSPEY S32 · 3/3L

John Drewry: Deeside Book Part 2 · Crib: MiniCribs · Diagram: Keith Rose's Diagrams

- 1-8** All petronella turn into the centre & set to partner, turn 2H 1.1/4 times back to places
- 9-16** 1s+2L & 3s+2M dance RH across, 2s pass RSh & dance LH across with other couple
- 17-24** 2s in prom hold dance reel of 3 with 1s passing 1L RSh, end 2s in centre at top
- 25-32** 2s+1s+3s dance Allemande

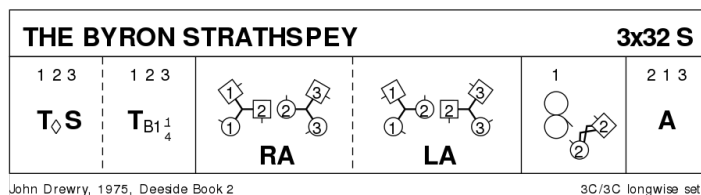

14 THE RECUMBENT STONE R48 · 5/5L

John Drewry: *The Greenburn Book 3 · Crib: MiniCribs · Diagram: Keith Rose's Diagrams*

- 1-8** 2s+3s+4s circle 6H round & back **while** 1s & 5s wait for 4 bars then turn RH for 4 bars
- 9-16** 1s & 3s dance Fig of 8 round couples below them
- 17-24** 1s & 3s dancing between couple below turn them with nearer hand 1.1/2 times, cast down behind next couple & lead up LH to face 1st corners
- 25-32** 1s & 3s dance 1/2 diag reel of 4 with 1st corners, pass RSh & dance 1/2 diagonal reel of 4 with 2nd corners, 1s pass RSh to face 3rd corners
- 33-40** 1s & 3s dance 1/2 diag reel with 3rd crnrs & pass RSh to face partner in centre (Ladies face down & Men up) & dance 1/2 reel of 4 in up/down
- 41-48** 3s & 1s turn RH 1.1/4 times to 2nd/4th places (opp side). 3s+1s dance 1/2 Figs 8 across (Ladies dance up, Men down, 3M+1L pass RSh) End 5 3 4 1 2

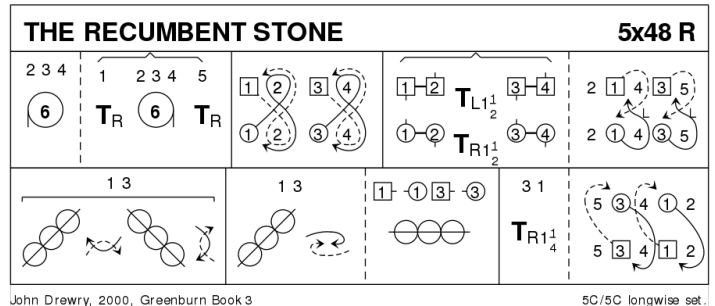

15 NEWBURGH JIG J32 · 3/4L

Allana Creighton: *RSCDS XLVIII 1 · Crib: MiniCribs · Diagram: Keith Rose's Diagrams*

- 1-8** 1s+2s+3s dance 6H round and back
- 9-16** 1s set, cast off (2s step up), turn LH to face 1st corners
- 17-24** 1s+ 1st corners set, 1s dance round each other by right to face 2nd corners. 1s + 2nd corners repeat, 1s finish in middle facing own sides, 1M below 1L
- 25-32** 1L+2s also 1M+3s dance LH across. 1s finish in 2nd place opposite sides. 2s+1s+3s set, 1s cross RH to 2nd place own sides

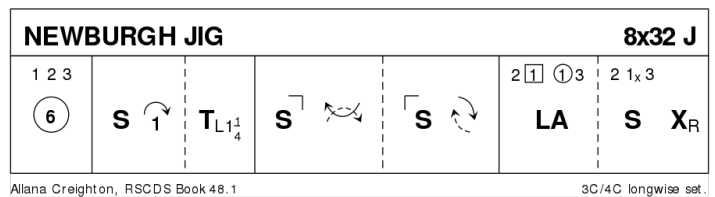

16 SAINT COLUMBA'S STRATHSPEY S32 · 5/5L

Vicky Sproule & Sadie L. Gillan: *Saint Columba's Strathspey (Leaflet) · Crib: MiniCribs · Diagram: Keith Rose's Diagrams*

- 1-8** 2s+4s dance RH across, 2s dance up **while** 4s dance down, 2s & 4s casting round ends on own sides to face 1st corners
- 9-16** 2s+4s Pass+Turn with 1st corners, pass partner LSh & Pass+Turn with 2nd corners & into centre facing partner (L facing down M up)
- 17-24** 2s+4s dance reel of 4 ending in original places on sides
- 25-32** 2s & 4s set & cast down 1 place **while** 3s & 5s set & dance up 1 place, 1s & 2s turn RH & cast down 1 place. 3 1 5 2 4

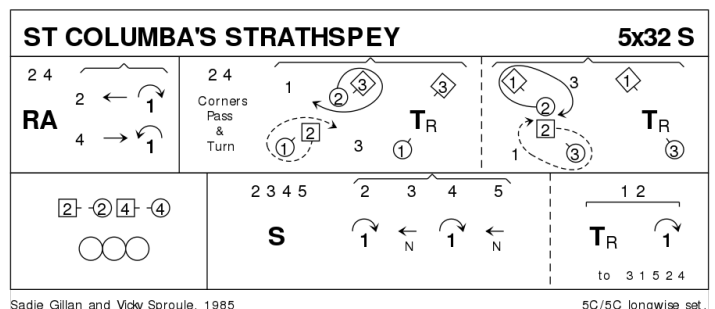

17 TRIP TO TIMBER RIDGE R32 · 3/4L

Linda Henderson: RSCDS LII 12 · Crib: MiniCrib · Diagram: Keith Rose's Diagrams

- 1-8** 1s turn RH, cast (2s step up) then 1L+2s & 1M+3s dance RH across. 1s end facing 1st corners
- 9-16** 1s dance Corner Pass+Turn with 1st corners, pass RSh & repeat with 2nd corners. 1s pull back RSh to end BtoB in centre facing opp sides
- 17-24** 2s+1s+3s dance Double Triangles. Bars 23-24 1s petronella turn to 2nd place own sides
- 25-32** 2s+1s+3s circle 6H round and back

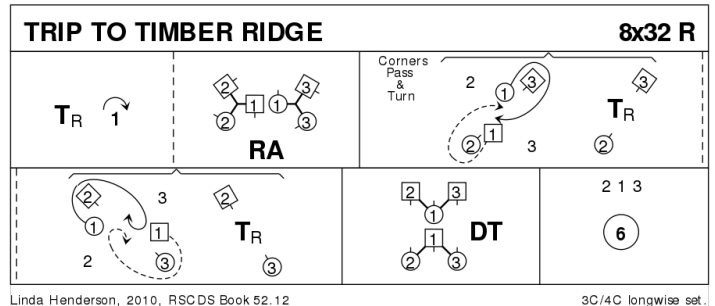

18 JEAN MARTIN OF ABERDEEN S32 · 3/3L

Muriel A Johnstone: Magazine Dances 2005-2009 · Crib: MiniCrib · Diagram: Keith Rose's Diagrams

- 1-8** 1s turn RH & cast 1 pl, all circle 6H round 3/4 way to left & end in lines of 3 across (Ladies face down & Men up)
- 9-16** All set & change places with partner RH, all circle 6H round 3/4 way to left & end in middle facing up. 3 1 2
- 17-24** All dance Allemande. 2 1 3
- 25-32** 1s+3s (bottom 2 couples) dance the Bourrel to end 2 3 1 :
1M+3L set advg, 3/4 turn 2H & twirl to end BtoB (up/down middle L facing up & M down) **while** 1L+3M chase anticlockwise 1/2 way to face prtner
1s+3s set to partners & turn 2H to own sides having changed places

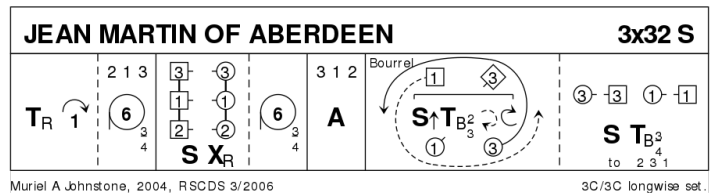

19 SUNSHINE AND SWEETIE'S JIG J32 · 3/4L

Mervyn C Short: RSCDS XLVIII 7 · Crib: MiniCrib · Diagram: Keith Rose's Diagrams

- 1-8** 1s+2s set, dance 1/2 RH across, set, cross RH
- 9-12** 1s+1st corners turn RH once round, 1s finish facing 1st corners
- 13-16** 1s+1st corners dance 1/2 diagonal reel of 4. Bars 15-16 1M (from 3rd place) & 1L (from 1st place) cross up/down to 2nd place own sides
- 17-24** 1s+2nd corners repeat 9-16 but turning LH and passing LSh to start reel. Bars 23-24 1M (from 1st place), 1L (from 3rd place) cross down/up to 2nd place own sides (3) 1 (2)
- 25-32** 3s+1s+2s chase anticlockwise 1/2 way round. 1s set and cross RH 2 1 3

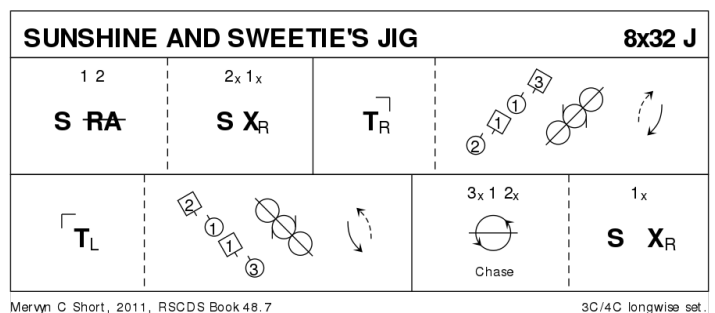

20 CRAMOND BRIDGE R32 · 3/4L

Valerie Farr: *The London Jubilee Book* (1979) · Crib: *MiniCribs* · Diagram: *Keith Rose's Diagrams*

- 1-8** 1s cross RH & cast 1 place, cross LH & cast (Lady up, Man down), to meet in middle in prom hold facing 2nd Man
- 9-16** 1s dance 1/2 diagonal reel with 1st corners & 1/2 reel with 2nd corners, end in middle facing Ladies' side
- 17-24** 1s lead out, cross & cast (Lady up, Man down) to meet in middle, 1s turn RH as 2s+3s dance 1/2 R&L round them
- 25-32** 1s lead up & cast to 2nd place & 2s+1s+3s turn partners RH

