

Blairgowrie Day School Dance

1 A TRIP TO BLAIRGOWRIE J40 · 3/4L

Evelyn Ramwell: The Third Kirkbrae Collection · Crib: MiniCribs

- 1-8 1s set, cross down RH to double triangle position with 2s+3s & set, 1s turn 1st corners RH into 2nd place opposite sides
- 9-16 1s dance reels of 3 on sides passing 2nd corners LSh & end crossing to 2nd place own sides
- 17-24 1s dance reels of 3 on own sides passing 3rd corner RSh
- 25-32 1s turn 3rd crnrs RH into lines of 3 across (1M between 2s facing down & 1L between 3s facing up) & all set, 1s pass RSh & cast to 2nd pl
- 33-40 2s+1s+3s circle 6H round & back

2 PORTNACRAIG R32 · 3/4L

Linda C Gaul: RSCDS XXXVI 1 · Crib: MiniCribs · Diagram: Keith Rose's Diagrams

- 1-8 1s set & 1/2 turn 2H to face 2s, set & 1/2 turn 2s (1M+2L turn RH as 1L+2M turn LH) to end in 2nd place on opposite sides
- 9-16 2s+1s+3s Adv+Ret 2 steps & circle 6H round 1/2 way to left
- 17-24 1s dance 1/2 Reels of 4 with 1st corners then 2nd corners to end in 2nd place opposite sides
- 25-32 1s dance 1/2 Fig of 8 round 3s & 2s+1s+3s turn RH

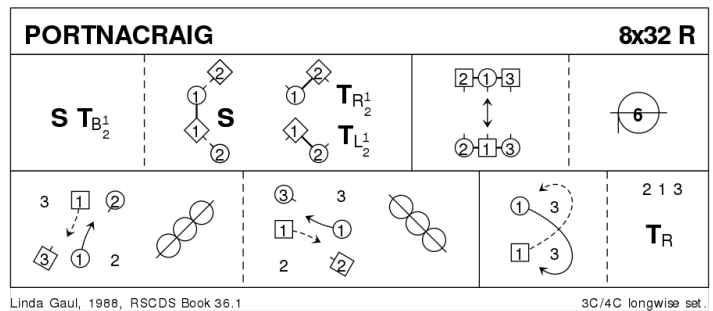

3 CITY OF BELFAST S32 · 3/3L

Lucy Mulholland: RSCDS XLVIII 6 · Crib: MiniCribs · Diagram: Keith Rose's Diagrams

- 1-8 1s dance 1/2 Fig of 8 round 2s, 1L+2M turn RH 1.1/4 times **while** 1M+2L turn LH 1.1/4 times & 1s end BtoB facing opp sides
- 9-16 1s+2s dance reel of 4 across & 2s end in 1st places **while** 1s pass LSh to face 1st corners
- 17-24 1s set to 1st corner & 2nd corner ending (turning to right) between corners, all set & 1s cross RH
- 25-32 1s+3s dance Espagnole:
 - 25-26 1s+3s cross (Ladies lead across RH passing between Men) with Ladies changing places RH
 - 27-28 1s+3s cross back (Men lead across RH between Ladies) with Men changing places RH
 - 29-32 3s turn RH as 1s turn LH to end 2 3 1

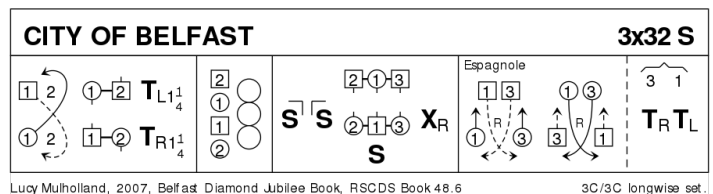

4 TEACHER'S CHOICE J

5 TEACHER'S CHOICE R

6 MISS ELEANOR S32 · 3/3L

Ann Dix: RSCDS XLIX 5 · Crib: MiniCribbs · Diagram: Keith Rose's Diagrams

- 1-8** 1s+2s+3s dance Mirror (Reflection) reels of 3 on sides (1s in/down to start)
- 9-16** 1s set, cast (2s step up) & turn RH. 1L casts to 3rd place, 1M casts up to 1st place (2M steps down & 3L steps up)
- 17-24** All dance 3 couple Bourrel:
17-20 1M+3L also 2M+1L set advcg & 3/4 turn 2H to line up/down middle then pull back RSh turning to face own prttrs as 3M & 2L chase anticl'wise to face them
21-24 All set & turn 2H to own sides. 3 1 2
- 25-32** 3s+1s+2s circle 6H round & back

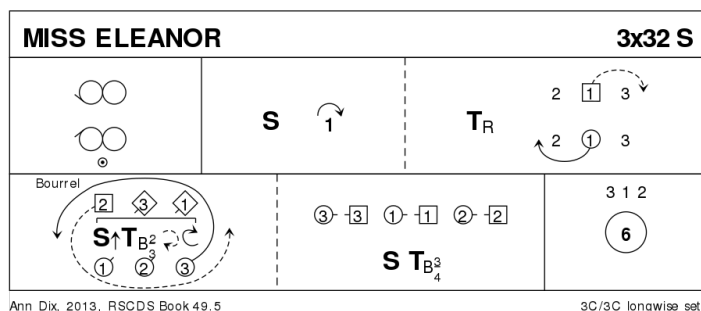

7 THE PINES OF PITLOCHRY J48 · 3/4L

Sam Firth: Scottish Dance Archives · Crib: MiniCribbs · Diagram: Keith Rose's Diagrams

- 1-8** 1s cross RH & cast 1 place, 1L dances 1/2 Fig of 8 round 2s & 1M round 3s end in centre each facing 1st corner & holding LH
- 9-16** 1s set to 1st corners, turn inwards & set to 3rd corner, 1/4 turn RH & set to 2nd corners, turn inwards & set to 4th corner
- 17-24** 1L with 2s & 1M with 3s dance RH across, 1s turn 1.1/2 times LH in centre **while** 2s & 3s chase round clockwise 1/2 way
- 25-32** 1L with 2s & 1M with 3s dance RH across (same couple but at other end), 1s turn 1.1/2 LH **while** 2s & 3s chase round clockwise 1/2 way
- 33-40** 1L with 2s & 1M with 3s dance full LSh reels of 3, 1s ending on own sides in 2nd place
- 41-48** 2s+1s+3s circle 6H round & back

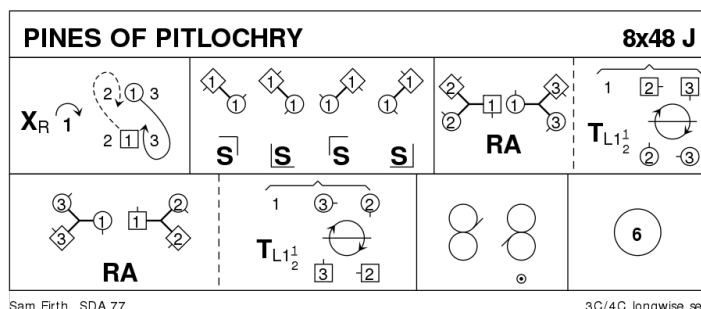

8 THE COUNTESS OF DUNMORE'S REEL R32 · 3/4L

Deirdre MacCuish Bark: RSCDS XLIX 12 · Crib: MiniCribS · Diagram: Keith Rose's Diagrams

- 1-8** 1s set, dance down below 3s, cast up to 2nd place & set advancing to face 1st corners (2s step up 3-4)
- 9-16** 1s turn 1st corners RH, pass RSh, turn 2nd corners RH, pass RSh to 2nd place own side facing out (corners dance 4 bars)
- 17-24** Promenade (Chaperoned) Chain progression:
17-18 1M casts up, 1L casts down as 2s+3s turn 3/4 RH into line up/down set
19-22 1M+2L & 1L+3M, in prom hold dance clockwise to opp end of line as 2M+3L (in middle) turn 1.1/2 LH
23-24 1s dance clockwise to 2nd place own side as 3s+2s turn partners 3/4 RH to own sides. All face clockwise 3 1 2
- 25-32** 3s+1s+2s dance clockwise 1/2 round set. All set, cross RH to own sides. 2 1 3

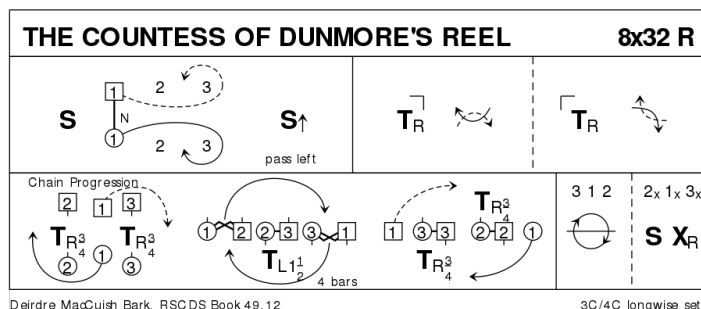

9 THE DREAM CATCHER S96 · 4S

Eileen Orr: RSCDS XLV 9 · Crib: MiniCribS · Diagram: Keith Rose's Diagrams

- 1-8** All circle 8H round & back
- 9-16** 1s+3s dance the Swirl: Turn partner RH into Allemande hold & dance LSh round other couple 1/2 way, dance LH across & swirl to face side couples (BtoB with ptrn & Lady facing Man)
- 17-24** All dance reels of 4 across
- 25-32** All set & dancing couples dance out between side couples, cross & cast to change places RH with partner back into places
- 33-40** All set & advance with partners, retire diagonally with corners & set
- 41-48** 1L+4M dance R&L with 3L+2M (on diagonal)
- 49-56** 1M+2L dance R&L with 3M+4L (other diagonal)
- 57-64** All set with corners, Adv+Ret with partners & set
- 65-88** 2s & 4s repeat bars 9-32
- 89-96** All circle 8H round & back

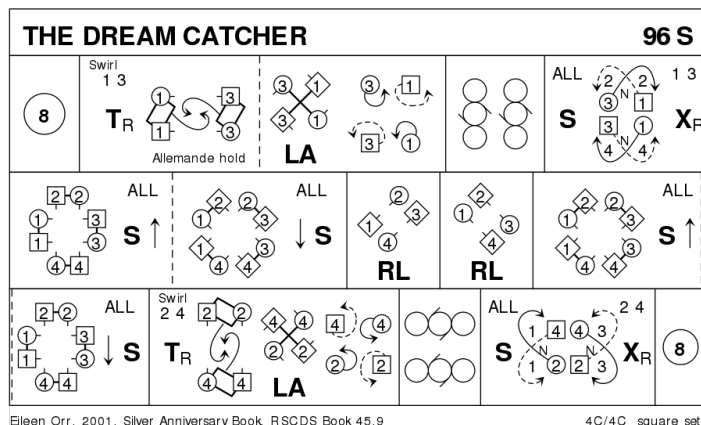

10 WE'VE NAE ELECTRIC R32 - 5/5L

Gary Coull: Jubilee Book 1929-2004 [Banffshire] · Crib: MiniCribbs · Diagram: Keith Rose's Diagrams

- 1-8** 1s+3s cross down RH into double triangle position & set, dance round 1st corner into a line up/down middle facing partner
- 9-16** 1s+3s dance reel of 4 **while** 2s+4s+5s dance reels of 3 on sides (4M in & up, 4L in & down to start)
- 17-24** 1s & 3s 1/2 turn partner RH, dance RSh round 2nd corner & turn partner RH 1.1/2 times to 2nd/4th place own sides
- 25-32** 1s+4s also 3s+5s Set+Link & all turn RH to end 2 4 1 5 3

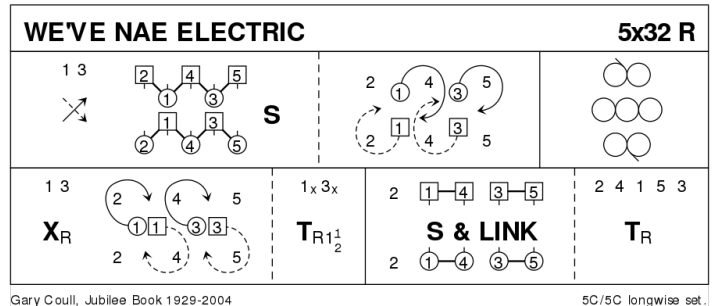

11 DUKE OF PERTH R32 - 3/4L

RSCDS 1 8 · Crib: MiniCribbs · Diagram: Keith Rose's Diagrams

- 1-8** 1s turn RH, cast to 2nd place, turn LH to face 1st corners
- 9-16** 1s turn 1st corner, partner, 2nd corner, & partner to face 1st corners
- 17-24** 1s set to & turn 1st corner 2H, set to & turn 2nd corner
- 25-32** 1s dance Reel of 3 on opposite sides giving LSh to 1st corner & cross back to own sides

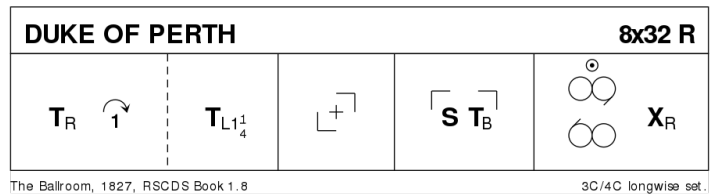

12 ROYAL GEORGE ON THE TAY S32 - 3/4L

Jon Allen-Friend: Six original Scottish country dances · Crib: MiniCribbs · Diagram: Keith Rose's Diagrams

- 1-8** 1s+2s dance the Tourbillon: 1s & 2s turn partners 2H 1/2 way, 1M & 2L lead partners on 1 place clockwise to end 1s on Ladies side & 2s on Men's side, 1s set to 2s
1s & 2s 1/2 turn partners 2H, 1L & 2M lead partners on 1 place to end 2s in 1st place & 1s in 2nd place. 2s cross RH to own side **while** 1s pass RSh on bars 7+8 to face out.
- 9-16** 2s+1s+3s reel of 3 on the sides (1M RSh to 2M, 1L RSh to 3L to start)
- 17-28** 2s+1s+3s dances R&L for 3 couples
- 29-32** 2s+1s circle 4H round to the Left

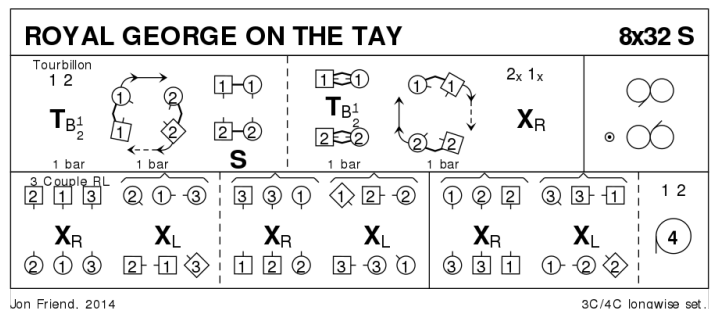

13 THE WATERNISH TANGLE J32 · 3/4L

Andrea Barfoot: The Skye Collection Vol 2 · Crib: MiniCribs · Diagram: Keith Rose's Diagrams

- 1-8** 1s cross down RH, set, cross down LH & set
- 9-16** 1s cross RH, change places on sides with 3s LH, 2s+1s cross RH & 3/4 turn LH on sides to form line of 4 across
- 17-24** 2s+1s dance the Targe :
17-18 1st & 2nd Ladies 3/4 turn RH **while** Men dance 1/4 way round anticlockwise
19-20 1st Man with 2nd Lady & 1st Lady with 2nd Man full turn LH
21-22 1st & 2nd Ladies 3/4 turn RH **while** Men dance 1/4 way round anticlockwise
23-24 1st Man with 2nd Lady & 1st Lady with 2nd Man turn LH to end on sides to 2(1)3
- 25-32** 1s cross down below 3s, cast up, dance up between 2s & cast to 2nd place

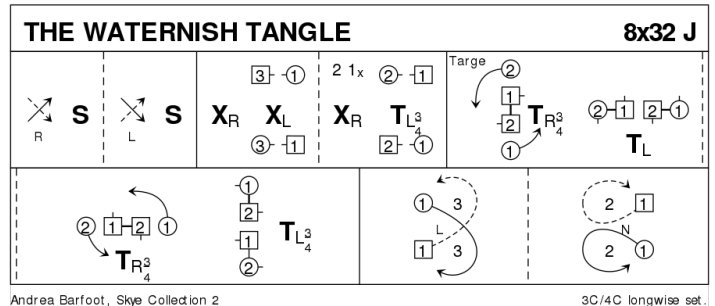

14 THE RECUMBENT STONE R48 · 5/5L

John Drewry: The Greenburn Book 3 · Crib: MiniCribs · Diagram: Keith Rose's Diagrams

- 1-8** 2s+3s+4s circle 6H round & back **while** 1s & 5s wait for 4 bars then turn RH for 4 bars
- 9-16** 1s & 3s dance Fig of 8 round couples below them
- 17-24** 1s & 3s dancing between couple below turn them with nearer hand 1.1/2 times, cast down behind next couple & lead up LH to face 1st corners
- 25-32** 1s & 3s dance 1/2 diag reel of 4 with 1st corners, pass RSh & dance 1/2 diagonal reel of 4 with 2nd corners, 1s pass RSh to face 3rd corners
- 33-40** 1s & 3s dance 1/2 diag reel with 3rd crnrs & pass RSh to face partner in centre (Ladies face down & Men up) & dance 1/2 reel of 4 in up/down
- 41-48** 3s & 1s turn RH 1.1/4 times to 2nd/4th places (opp side). 3s+1s dance 1/2 Figs 8 across (Ladies dance up, Men down, 3M+1L pass RSh) End 5 3 4 1 2

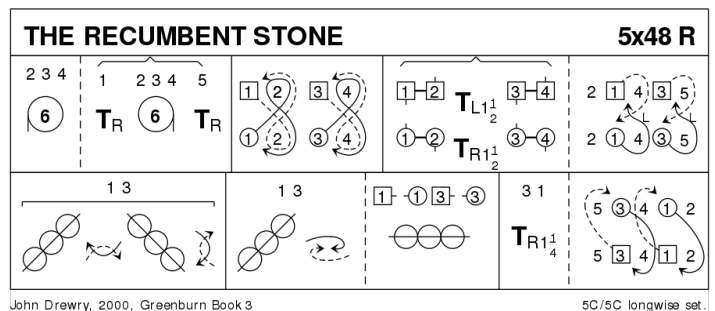

15 TEACHER'S CHOICE S

16 TEACHER'S CHOICE J

17 LET'S HAVE A CEILIDH R32 · 4/4L

Robert M Campbell: Glasgow Assembly And Other Scottish Dances · Crib: MiniCribbs · Diagram: Keith Rose's Diagrams

- 1-8** 1s & 4s cross RH & cast in 1 place, 1s+4s dance LH across (1s+4s end BtoB in centre facing corners)
- 9-16** All set & change places RH with corners, set & change back with LH
- 17-24** 1s+4s dance RH across & LH back **while** 2s+3s chase all the way round anticlockwise
- 25-32** All set & 1s+4s 1/2 turn partner RH, 1M+4L chase clockwise 1/2 way as 1L+4M 1/2 turn LH, 4s+1s cross RH to 2 4 1 3

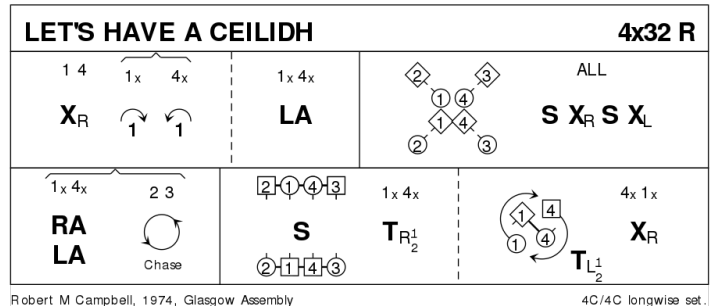

18 BROADWAY S32 · 3/3L

Chris Ronald: The Sunday Class Dance Book 2 · Crib: MiniCribbs · Diagram: Keith Rose's Diagrams

- 1-8** 1s dance down (2 bars) & turn 2H (2 bars), 1s dance up & cast to 2nd place
- 9-16** 2s+1s+3s Set+Link for 3, 1s dance 1/2 Diag R&L starting Diagonally left
- 17-24** All Set+Link for 3, 1s dance 1/2 Diag R&L starting Diagonally left. (3)(1)(2)
- 25-32** All set & 1/2 turn RH, face partner and pull back RSh, dance out to places & set. 3 1 2

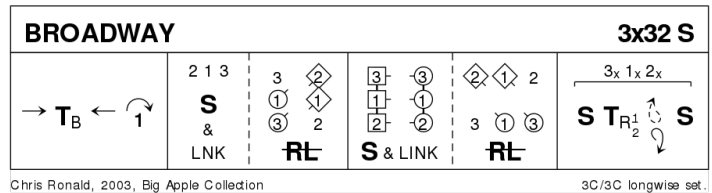

19 COLIN'S KILTS J40 · 3/4L

Margaret Young: A Book of Perth Dances · Crib: MiniCribbs · Diagram: Keith Rose's Diagrams

- 1-8** 1s+3s dance RH across 1/2 way, 1/2 turn partners RH & 1M leads his partner up behind 2M to end in 1st places (opposite sides) **while** 3L leads her partner down behind 2L to end in 3rd place opposite sides
- 9-16** 1s+3s repeat (from opposite sides) ending in original places
- 17-24** 1s+2s+3s dance RSh reels of 3 & 1s+2s change places RH on sides
- 25-32** 2s+1s+3s set twice & turn partners RH
- 33-40** 2s+1s+3s circle 6H round to left for 6 steps, pivot left & chase back to places

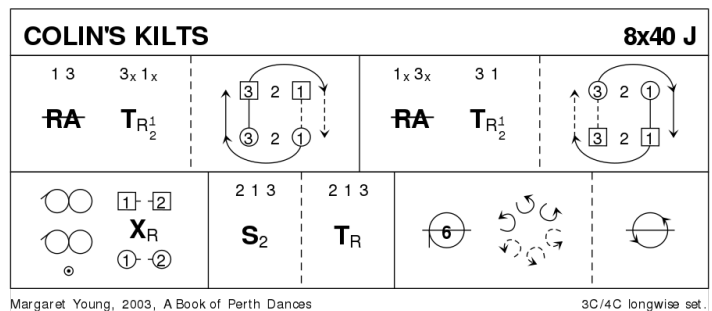

20 THE DEIL AMANG THE TAILORS

R32 · 3/4L

RSCDS XIV 7 · Crib: MiniCribs · Diagram: Keith Rose's Diagrams

- 1-8** 1s+2s set & dance RH across 1/2 way, set & dance LH across 1/2 way back to place
- 9-16** 1s lead down the middle & back to top
- 17-24** 1s+2s dance Allemande
- 25-32** 2s+1s+3s circle 6H round & back

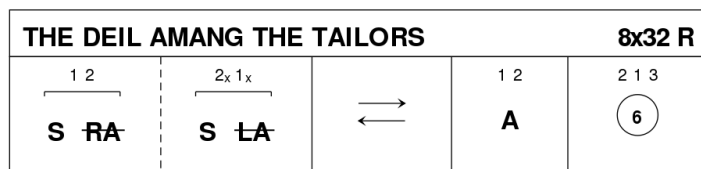

Davies Collection, RSCDS Book 14.7

3C/4C longwise set.