

Laurencekirk, Dickson Hall. Sat 17 Nov

1 THE HIGHLAND RAMBLER R40 · 3/4L

Roy Goldring: Silver Jubilee 25 - Leeds Branch · Crib: MiniCribS · Diagram: Keith Rose's Diagrams

- 1-8 1s dance in & cast to 2nd place, dance RH across with 3s
- 9-16 2s+1s dance LH across, 1L followed by partner cast up round 2L & dance down middle to 1L between 3s & 1M between 2s
- 17-24 1s+2s+3s dance down the middle & back
- 25-32 1M followed by partner cast down round 2L to 2nd places on own side & turn RH
- 33-40 2s+1s+3s circle 6H round & back

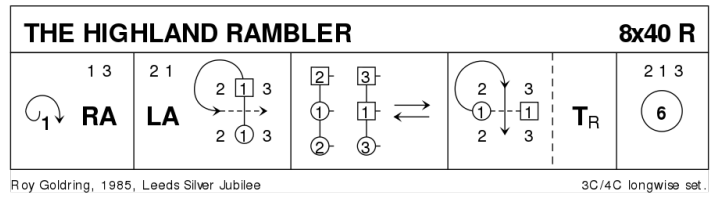

2 DANCING SPIRIT J32 · 3/4L

Amy Luxton-Esler: RSCDS L 11 · Crib: MiniCribS · Diagram: Keith Rose's Diagrams

- 1-8 1s turn RH moving down to face 3rd corners (2s step up 1-2). 1s+3rd corners (2M+1s+3L) dance 1/2 reel of 4. 1s pass LSh to face 4th corners
- 9-12 1s+4th corners (2L+1s+3M) dance 1/2 reel of 4.
- 13-16 1s dance RSh round 4th corner (pstrn) & join RH, 1s joining LH with 3rd corner pstrn (1L+2M, 1M+3L) in Bal-in-Line position
- 17-24 1s+2s+3s dance 'The Spoke'. Bars 23-24 1s retain RH, turn to 2nd place opp sides (skip change) while 3s+2s set. (3) (1) (2)
- 25-32 3s+1s+2s dance clockwise 1/2 round then turn partners RH once round

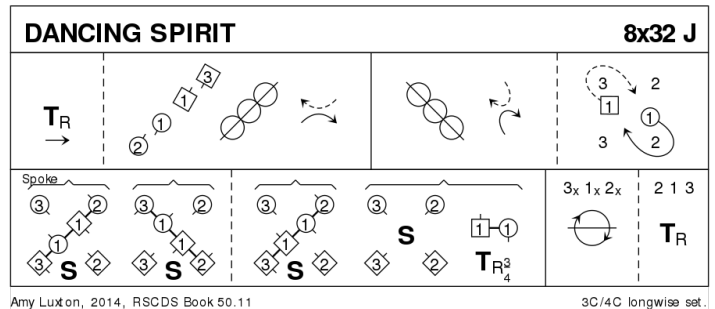

3 THE ROSE OF THE NORTH S32 · 3/4L

Roy Goldring: Silver Jubilee 25 - Leeds Branch · Crib: MiniCribS · Diagram: Keith Rose's Diagrams

- 1-4 1s lead down below 3s, cross & cast up to 2nd place on opposite side
- 5-16 2s+1s+3s dance 3 couple R&L, 1s end facing 1st corners
- 17-24 1s set & turn 1st corner 2H, set & turn 2nd corner 2H. 1s finish BtoB in centre, 1M facing up, 1L facing down
- 25-32 1s circle 3H round to left (Man with 2s & Lady with 3s), 1s pull back RSh to face each other & set, 1s Petronella turn to 2nd place own side

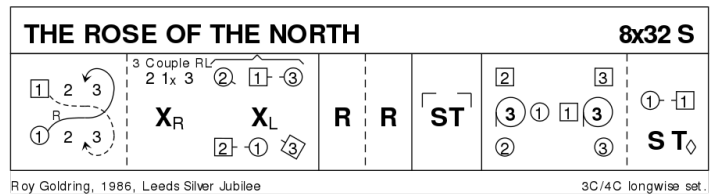

4 ORPINGTON CALEDONIANS R32 · 3/4L

John Brenchley: RSCDS XLIX 2 · Crib: MiniCrib · Diagram: Keith Rose's Diagrams

- 1-8** 1s set, 1L casts & followed by 1M, dances across to 2M's place facing out (2s step up 5-6). 1L+3M also 1M+3L
1/2 turn LH & Men face out
- 9-16** 3s+1s dance Ladies' Chain, 1M finishes facing out
- 17-24** 1M followed by 1L casts up, dances across to 2M place (3s step down 19-20). 2s+1s dance RH across. 1M & 2L face out
- 25-32** 2s+1s+3s dance reels of 3 on sides (1s+3s pass LSh to start)

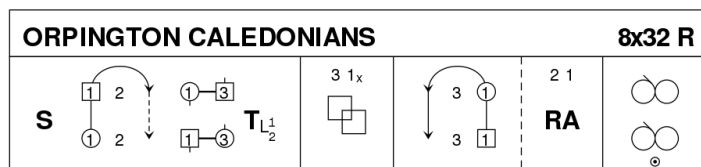

John Brenchley, 1987, RSCDS Book 49.2

3C/4C longwise set.

5 TRIBUTE TO THE BORDERS J32 · 3/4L

Roy Goldring: The Leaflet Dances with Music · Crib: MiniCrib · Diagram: Keith Rose's Diagrams

- 1-8** 1s cross RH & cast 1 place, turn RH 1.1/2 times to end in prom hold facing 2M
- 9-16** 1s dance 1/2 RSh reel of 3 on Mans side, cross to face 3L & dance 1/2 RSh reel on Ladies side 1s end facing 3L (in top place)
- 17-24** 1s set to 3L, turn & set to 2L, turn & set to 2M, turn & set to 3M ending with 3s+1s+2s in centre ready for Allemande
- 25-32** 3s+1s+2s Allemande

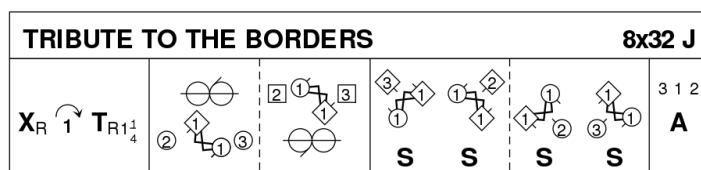

Roy Goldring, 1979, RSCDS Leaflet 11

3C/4C longwise set.

6 ROUGEMONT CASTLE S32 · 3/3L

Duncan Brown: RSCDS XLVIII 12 · Crib: MiniCrib · Diagram: Keith Rose's Diagrams

- 1-8** 1s lead down to bottom & cross to cast up to 2nd pl on opp sides, 1s dance 1/2 Fig of 8 (L up round 2s, M down). 2 1 3
- 9-16** All cross RH & chase clwise 1/4 way into lines across, all change places with partner RH & chase clwise to opp sides. (3)(1)(2)
- 17-24** 1s change places RH with person diagonally to right & new centre couple LH with person diag left, new centre cpl RH diag right & 2s (at top) cross RH as 1s & 3s 1/2 turn RH into Allemande hold
- 25-32** 1s+3s dance Allemande. 2 3 1

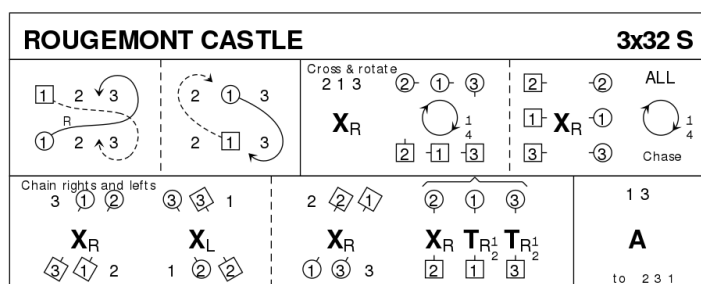

Duncan Brown, Exeter Branch 40, RSCDS Book 48.12

3C/3C longwise set.

7 THE PATCHED BAGPIPE J32 · 4/4L

John W Mitchell: *Whetherly Book 22 · Crib: MiniCrib*s

2 chords - 2nd chord 3s & 4s cross to opp side

- 1-4 1s+2s also 3s+4s dance RH across. 1L & 4L finish facing out, 2M facing down, 3M facing up
- 5-8 2s+3s dance LH across **while** 1s & 4s chase clockwise 1/2 round to opposite end
- 9-16 Parallel RSh reels of 4 on sides
- 17-24 All change places RH on sides retaining hands & all Bal-in-Line. 1M+4L also 1L+4M turn LH and Men face out
- 25-32 1s+4s dance Ladies' Chain, Men casting up/down on sides to start. Men omit polite turn at end ready for RH across in next time through

8 MRS MACPHERSON OF INVERAN R32 · 3/4L

John Drewry: *Bon Accord Book of Scottish Country Dances · Crib: MiniCrib*s · Diagram: Keith Rose's Diagrams

- 1-8 1s dance Inveran Reels with 2s+3s
- 9-16 1s turn RH 1.1/2 times moving down to 2nd places (opposite sides), 1s cast up behind 2s & cross down to 2nd place own side
- 17-24 2s+1s+3s dance Grand Chain
- 25-32 2s+1s+3s circle 6H round & back

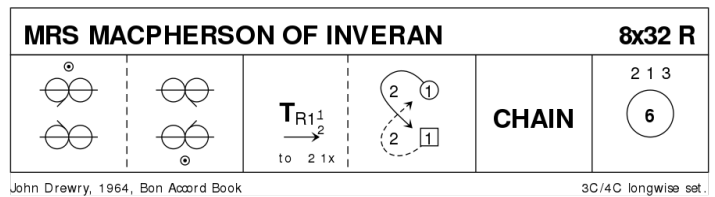

9 192 MILES HOME J48 · 4S

Katy Sweetman: *RSCDS L 4 · Crib: MiniCrib*s · Diagram: Keith Rose's Diagrams

Note: All turns with Elbow Grip - RE=Right Elbow, LE=Left Elbow

Part A

- 1-8 1s NHJ dance between 3s, separate, cast into centre & dance out between 2s/4s back to place (1M between 2s, 1L between 4s)
- 9-16 1s turn RE, turn corners LE, 1s turn RE, 1M+2M also 1L+4L turn LE
- 17-24 1s turn RE, 1M+3L also 1L+3M turn LE. 1s dance to original places facing out, set & turn inwards to face partner

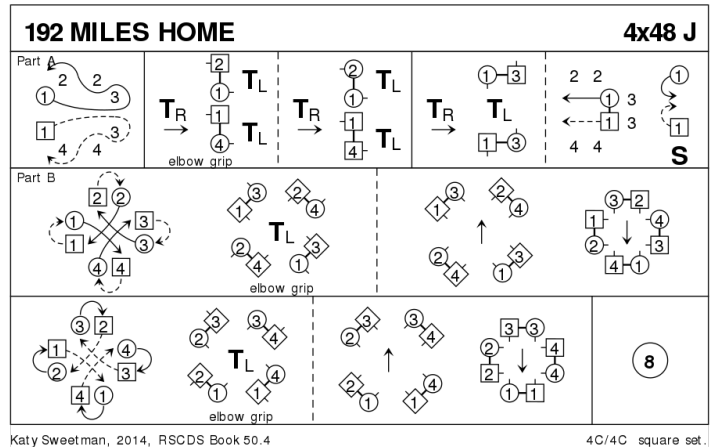

Part B

- 1-4 Men pass LSh dancing to Right into next Lady's place, face out **while** Ladies cast to partner's place & face in. All turn corner (dancer on Left) LE to finish NHJ with corner facing in
- 5-8 All Advance with corner & Men Retire with Lady on Left
- 9-12 Ladies leading, all repeat bars 1-4
- 13-16 All Advance with corner & Men Retire with partner to new position (1 place round anticlockwise)
- 17-24 All circle 8H round & back

10 THE QUERN S32 · 3/3L

John Bowie Dickson: Dunedin Dances Book 3 · Crib: MiniClibs · Diagram: Keith Rose's Diagrams

- 1-8** 1s & 3s set & 3/4 turn RH into middle & dance 1/2 reel of 4 up/down ending with 1M+3L turning LH 3/4 to face 2s (Man facing Lady)
- 9-16** 1M+3L+2s dance 1/2 reel of 4 across & end by turning LH to face partners, 3s+1s dance 1/2 reel of 4 in centre
- 17-24** 1s & 3s set to prttrs & 3/4 turn to opp side, 1s change pls on sides with 2s (1s dance b'tw'n 2s), 1s change pl with 3s (3s b'tw'n 1s) (All on opp sides)
- 25-32** All dance reels of 3 on sides each couple crossing up from bottom place (starting with 1s) & 3s dance out & down to start. 2 3 1

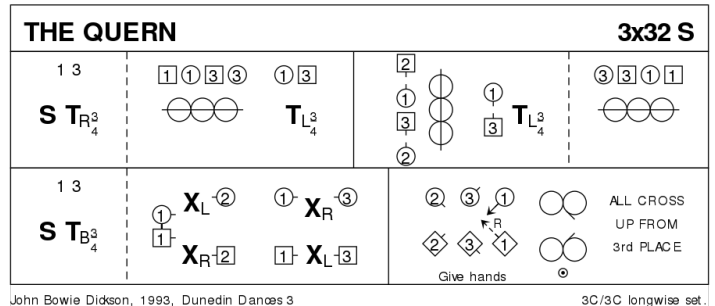

John Bowie Dickson, 1993, Dunedin Dances 3

3C/3C longwise set.

11 NEWARK CASTLE J48 · 4S

Pat Harland: The Sunday Class Dance Book 2 · Crib: MiniClibs · Diagram: Keith Rose's Diagrams

- 1-8** 1s set, cross (no hands) into centre. 1L+2s dance LH across as 1M+4s dance RH across
- 9-16** 1s cross between 3s, cast round set to place & set
- 17-24** All Advance with partner, Retire with corner. All couples Set+Link
- 25-32** All Advance with corner, Retire with next person to form square set. All couples Set+Link
- 33-40** Dancers in 1st+3rd places (2M+4L & 2L+4M) dance 1/2 R&L, then dance 1/2 Ladies' Chain
- 41-48** Dancers in 2nd+4th places repeat 33-40. All have moved 1 place anti-clockwise

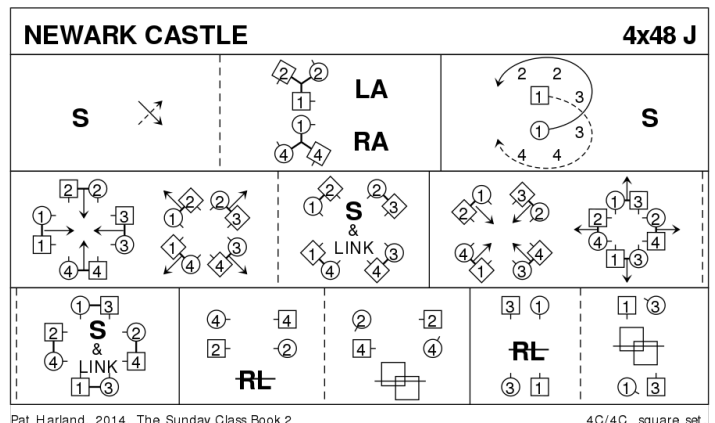

Pat Harland, 2014, The Sunday Class Book 2

4C/4C square set.

12 TOAST TO THE MOUSIES R32 · 3/4L

Sara Gratiot · Crib: E-cribs · Diagram: Keith Rose's Diagrams

- 1-- 1c long cast to 2pl (2c up) ; dance between 3c and cast up (2,1,3)
- 9-- 2c+1W & 1M+3c RHA ; 2c+1M & 1W+3c LHA, finish 2c in 1pl facing 3c in 3pl, both NHJ, and 1c BtoB in middle, M facing up, W down
- 17-- All set | 2c+3c, making arches, dance to meet as 1c dance under, finish 1c (in 1pl/3pl) facing P on midline and 2c+3c BtoB in middle, NHJ ; All set | 2c+3c making arches dance to ends, and cast into the reel **while{2}** 1c dance under arch passing P Lsh and finish between end cpl, facing 1cnr
- 25-- 2c+1W & 1M+3c Lsh Reels3{6} across (2c+3c with loops) (to 2,1,3) | All set

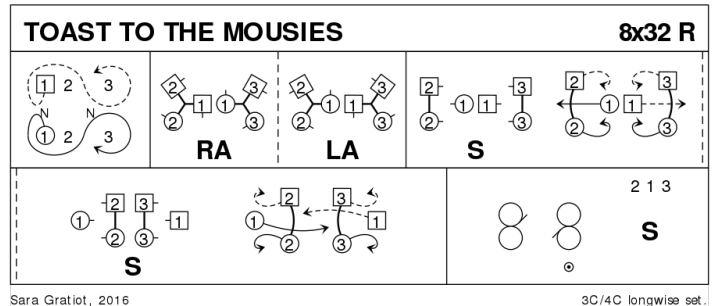

Note: after 2nd time through 1c may repeat [1-4] to get to 4pl.

13 DALKEITH'S STRATHSPEY S32 · 3/4L

RSCDS IX 6 · Crib: MiniCribs · Diagram: Keith Rose's Diagrams

- 1-8 1s (with nearer hands joined) set to 2L & circle 3H round to the left, set to 2M & circle 3H round to the left
- 9-16 1s lead down the middle (2s step up) & back to end between 2s (BtoB) facing opposite partners
- 17-24 1s+2s dance reel of 4 across, 1s end in middle facing 1st corner
- 25-32 1s turn 1st corner RH, partner LH, 2nd corner RH & cross LH to own sides

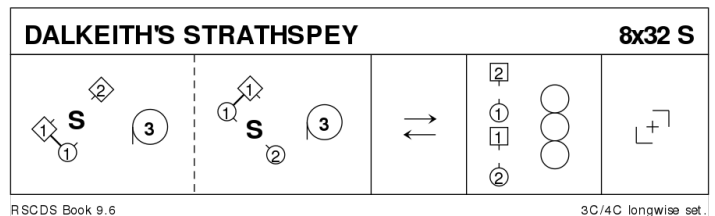

14 NAPIER'S INDEX J40 · 3/4L

Brian Charlton: RSCDS XLV 8 · Crib: MiniCribs · Diagram: Keith Rose's Diagrams

- 1-8 1s set & cast 1 place, turn LH 1.1/4 times to end in Bal-in-Line position between 1st corners
- 9-16 1s+1st corners Bal-in-Line & turn corners RH (4 bars) to Bal-in-Line again with 1st corners
- 17-24 1s dance reel of 3 on sides (LSh to 2nd corner) & end diagonally between 2nd corners
- 25-32 1s+2nd corners Bal-in-Line & turn corners RH (4 bars), Bal-in-Line again with 2nd corners
- 33-40 1s dance reels of 3 across (LSh to 3rd corners) & cross RH to 2nd places

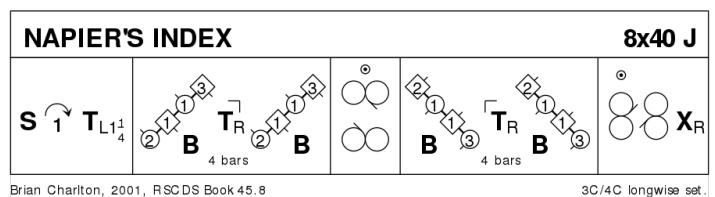

15 JAMES GRAY J32 · 4/4L

Ronella Burrows: RSCDS XLII 10 · Crib: MiniCribbs · Diagram: Keith Rose's Diagrams

3s & 4s start on opp sides

- 1-8** 1s & 4s cross RH, cast 1 place, 1s dance 1/2 Fig of 8 round 2s **while** 4s dance 1/2 Fig of 8 round 3s
- 9-16** 1s+4s dance R&L & end 1s facing up & 4s down
- 17-24** All dance RSh reel of 4 on sides & end 1s+4s in line across (Men in centre RSh to RSh & 1M LSh to 4L & 4M LSh to 1L)
- 25-28** 1M+4M 3/4 turn RH **while** Ladies dance anticlockwise 1/4 way round, Men 1/2 turn other partner LH to bring Ladies into centre
- 29-32** 1L+4L 3/4 turn RH **while** Men dance anticlockwise 1/4 way round, Ladies 3/4 turn Men LH to end 1s in 3rd place opp sides & 4s in 2nd place

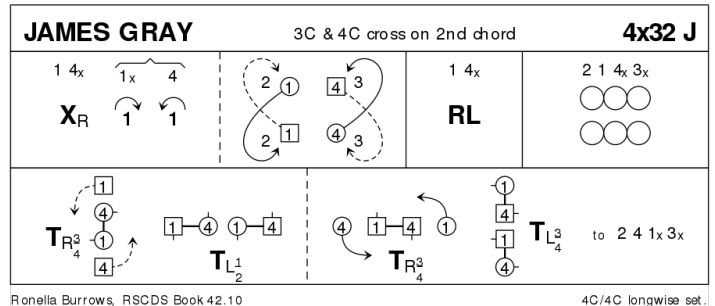

16 INDIAN RIVER STRATHSPEY S32 · 3T

George Senyk: Scottish Country Dances in Diagrams. Ed. 9 · Crib: MiniCribbs · Diagram: Keith Rose's Diagrams

- 1-8** 1s+2s+3s in prom hold dance a reel of 3 across the set, 1s passing 3s RSh to start
- 9-16** 1s (with Lady leading) dance RH across with 3s & dance LH across with 2s
- 17-24** 2s+3s dance Ladies Chain across the set **while** 1s set (2 bars) & then dance between 2s+3s & cast individually back to places
- 25-32** 1s+3s dance 1/2 R&L, 1s+2s dance 1/2 R&L to end 3 1 2

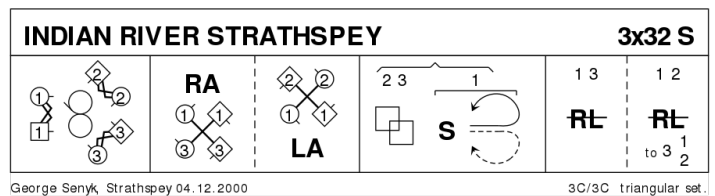

17 FESTIVAL FLING R32 · 3/4L

Lily Davison: RSCDS XLIV 7 · Crib: MiniCribbs · Diagram: Keith Rose's Diagrams

- 1-8** 1s set, cross RH, cast 2 places & dance up to face 1st corners
- 9-12** 1s set to 1st corner & change places RH with 1st corner persons passing LSh to face 2nd corners (M facing M & L facing L)
- 13-16** Original 1st corner persons set to 2nd corners & change places RH with 2nd corners passing LSh to face 1st corner (M facing M & L facing L)
- 17-20** Original 2nd corner persons set to 1st corners (1s), change places RH & 1s end facing opposite sides as for double triangles
- 21-24** All set, corner persons chase 1 place clockwise **while** 1s PdB round each other to face down (Man with partner on left)
- 25-32** 1s dance down between 3s, cast up to 2nd place, dance up between 2s & cast to 2nd place

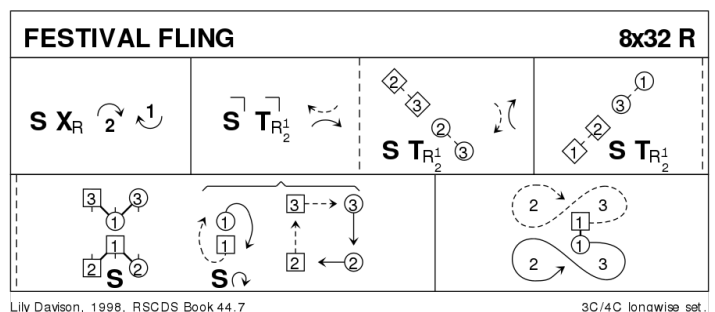

18 ST ANDREW'S FAIR J32 · 3/4L

Roy Goldring: Five Scottish Country Dances 1982 · Crib: MiniCrib · Diagram: Keith Rose's Diagrams

- 1-8** 1s cross RH, cast 2 places, cross LH below 3s & cast up to 2nd place own sides
- 9-16** 2s+1s+3s 1/2 turn RH retain hands & all set (M face down & L up) 2L leads Ladies across & down own side **while** 3M leads Men across & up
- 17-24** 3s+1s+2s circle 6H round & back
- 25-32** 3s+1s+2s 1/2 turn LH retain hands & all set (M face up & L down) 2L leads Ladies across & up own side **while** 3M leads Men across & down

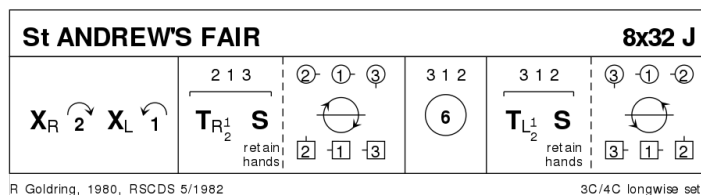

19 MACDONALD OF THE ISLES S32 · 3/3L

Derek Haynes: Carnforth Collection of SC Dances 2 · Crib: MiniCrib · Diagram: Keith Rose's Diagrams

- 1-8** 2s dance full diagonal Reels of 4 with 1st corners, passing by the LSh to face 2nd corners
- 9-16** 2s dance full diagonal Reel of 4 with 2nd corners to end in original places
- 17-24** All dance Snowball Grand Chain for 3 cples to end 3 (2) 1:
1s cross RH & change places LH on side with 2s
1s change places RH with 3s **while** 2s cross over RH
1s cross LH **while** 2s & 3s change places LH. 3 (2) 1
- 25-32** 3s+2s dance 1/2 R&L, 3s dance 1/2 Fig of 8 round end couples (3M up & 3L down) to end in 2nd places

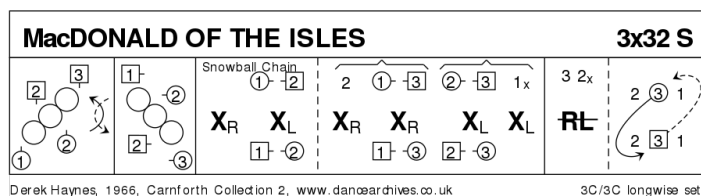

20 NOTTINGHAM LACE R96 · 4S

Jenny Bradley: Nottingham Lace · Crib: MiniCribbs · Diagram: Keith Rose's Diagrams

PART 1

- 1-8** All dance 1/2 Grand Chain & set to partners, 3/4 turn RH to end with Ladies in centre for LH across
- 9-12** Ladies dance LH across 1/2 way **while** Men dance 1/4 way round clockwise, Ladies 1/2 turn nearest Man RH
- 13-16** Men dance LH across 1/2 way **while** Ladies dance 1/4 way round clockwise & all 1/2 turn partners RH
- 17-24** All repeat bars 9-16 to original places

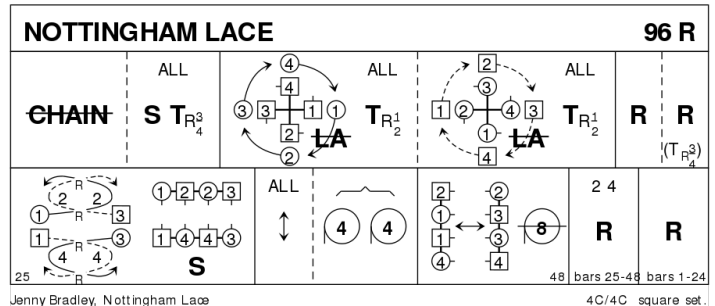

PART 2

- 25-32** 1L & 3M change places RH, cast behind 4s & change places RH to join end of line **while** 1M & 3L dance similarly behind 2s, all set
- 33-40** All Adv+Ret, 1s+2L+4M also 3s+2M+4L circle 4H round to left to end in line across (1s & 3s in centre of line)
- 41-48** All Adv+Ret, circle 8H round 1/2 way to end in Sq. Set opposite to original places

PART 3

- 49-72** Repeat PART 2 with 2s & 4s as dancing couples, all ending in original places

PART 4

- 73-96** Repeat PART 1

21 MAIRI'S WEDDING R40 · 3/4L

James B Cosh: Twenty Two SCD · Crib: MiniCribbs · Diagram: Keith Rose's Diagrams

- 1-8** 1s turn RH & cast to 2nd place, 1s turn LH to face 1st corners
- 9-16** 1s dance 1/2 diagonal reel of 4 with 1st corners, 1s dance 1/2 diagonal reel with 2nd corners
- 17-24** 1s dance 1/2 diagonal reel with 3rd corner (pstns), 1/2 diagonal reel with 4th corner (pstns)
- 25-32** 1s dance reel of 3 across (Lady with 2s, Man with 3s - LSh to 1st corner)
- 33-40** 2s+1s+3s circle 6H round & back

