

# Hogamany - Dunbar Street - 31 Dec 2018

## 1 CIRCASSIAN CIRCLE R32 · 1C

Source unknown · Crib: MiniCribs · Diagram: Keith Rose's Diagrams

All form circle around the room with partner on Man's right

- 1-8** All dance in 4 steps & out, repeat
- 9-16** Ladies dance in 4 steps, clap & out again, Men do the same but turn to face partner as they dance out
- 17-24** All swing partners & end facing anticlockwise round the room
- 25-32** All Promenade anticlockwise 8 steps [On bar 31 & 32, the man using his left hand passes his partner in front of him so that she finishes on his left. All men have a new partner on their right.]

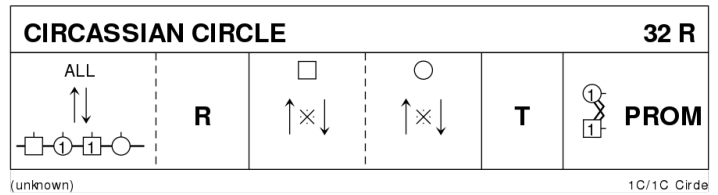

## 2 HOGMANAY JIG J32 · 3/4L

Christopher Blair: Two Scottish Country Dances · Crib: MiniCribs · Diagram: Keith Rose's Diagrams

- 1-8** 1s+2s+3s set, cross RH, all chase clockwise to own sides
- 9-16** 1s+2s+3s set, cross LH, all chase anticlockwise to own sides
- 17-24** 1M+3L change places RH, 1L+3M change places RH, 2s cross RH & 3s+2s+1s set. (3)(2)(1)
- 25-32** 3s+2s+1s dance modified Reverse Snowball Grand Chain for 3 cpls to end 2 1 3 :  
 1s cross LH, 1s+2s change places RH on side  
 1s change places LH with 3s **while** 2s cross LH  
 1s turn RH into 2nd place as 2s dance up own sides to top places **while** 3s cross down to original places. 2 1 3

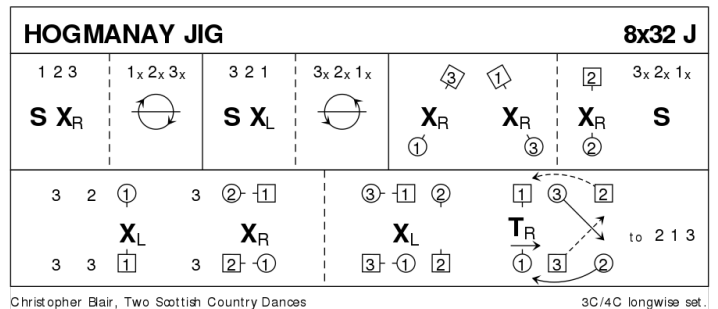

### 3 SANDS OF MORAR S32 · 3/4L

Barry Priddey: RSCDS XLV 6 · Crib: MiniCribS · Diagram: Keith Rose's Diagrams

- 1-8 1s dance Fig of 8 round 2s giving hands when possible
- 9-16 1s dance reflection reels of 3 on own sides (1s dance down between 2s to begin)
- 17-24 1s turn 2H & dance down middle to 3rd pl as 2s+3s continue reel & dance down behind 1s, all set & 1s followed by 2s+3s cast up to orig pls
- 25-32 1s+2s dance the Tourbillon :  
1s & 2s turn partners 2H 1/2 way, 1M & 2L lead partners on 1 place clockwise to end 1s on Ladies side & 2s on Men's side, 1s set to 2s  
1s & 2s 1/2 turn partners 2H, 1L & 2M lead partners on 1 place to end 2s in 1st pl & 1s in 2nd pl & 2s+1s cross RH to own sides

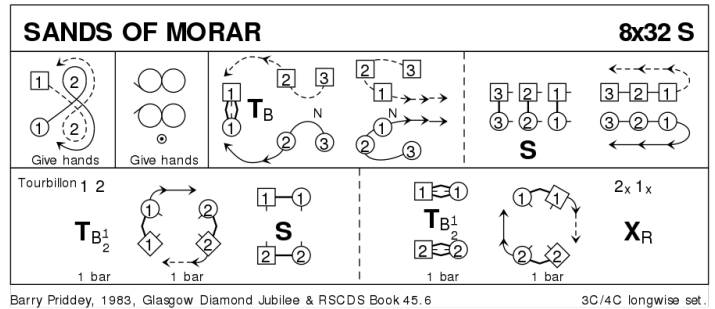

### 4 GLENMORANGIE R32 · 3/4L

John Drewry: Stoneywood Collection Volume 2 · Crib: SCDDDB Contributed CribS & Diagrams · Diagram: Keith Rose's Diagrams

- 1- 8 1s cross RH, cast (2s step up). 1M dances up, casts round 2M to 2nd place own side as 1L dances down, casts up round 3L to 2nd place own side
- 9-16 RSh reels of 3 on sides (1M RSh to 3M, 1L RSh to 2L), 1s pass LSh to face 1st corners
- 17-24 1s+1st corners set, 1s dance round each other by Right to face 2nd corners. 1s turn 2nd corners LH to finish on own sides End 2 1 3
- 25-32 1L+2s & 1M+3s dance RH across, 1s pass each other to dance LH across with other couple (1L+3s & 1M+2s)

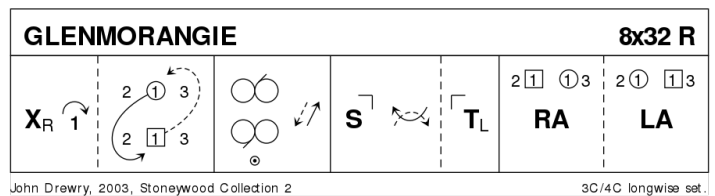

### 5 THE LAIRD OF MILTON'S DAUGHTER J32 · 3/4L

Craigmyle: RSCDS XXII 10 · Crib: MiniCribS · Diagram: Keith Rose's Diagrams

- 1-8 1s set, cross RH, cast 1 place & turn LH to face 1st corners
- 9-24 1s dance Corner Chain with 1st & 2nd corners :  
1s change pl RH with 1st crnrs, 1st crnrs turn LH in centre & return to places giving RH to 1s who turn LH in centre to face 2nd crnrs  
1s change places RH with 2nd crnrs, 2nd crnrs turn LH in centre & return to places giving RH to 1s & 1s end with a 1/2 turn LH to 2nd place own sides
- 25-32 2s+1s+3s circle 6H round & back

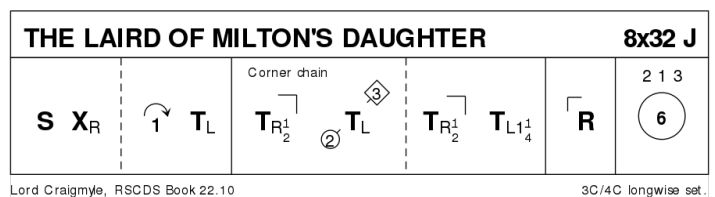

## 6 ORWELL LODGE STRATHSPEY

S32 · 3/3L

Ian Brockbank: QE Diamond Jubilee Dances · Crib: MiniCribs · Diagram: Keith Rose's Diagrams

- 1-8** 1s+2s dance the Knot & 1s end facing 1st corners
- 9-16** 1s dance 1/2 diagonal reel with 1st corners & pass RSh to face 2nd corners, 1s dance 1/2 diagonal reel with 2nd corners & end 2nd place opp sides
- 17-24** All set & corner persons cast clockwise 1 place as 1s petronella turn into middle, repeat bars 17-20 with 1s ending 2nd place own sides
- 25-32** All set & turn partners 2H, 1s+3s dance 1/2 Diagonal Poussette. 2 3 1

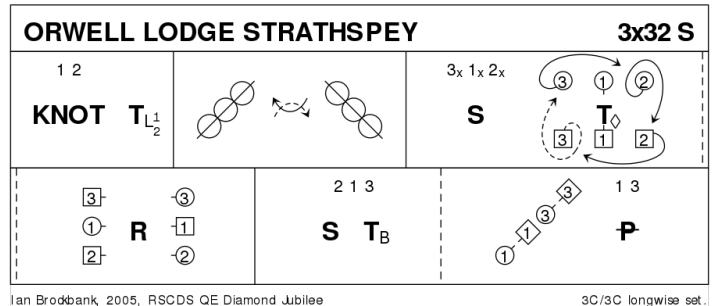

## 7 THE SPRIG OF IVY R32 · 3/4L

John Bowie Dickson: Celebrate Fifty Years of Dancing with the Boston Branch · Crib: MiniCribs · Diagram: Keith Rose's Diagrams

- 1-8** 1s set & cross down RH to 2nd place, set & turn LH 1 1/4 to face 2nd corners
- 9-16** 1s dance Pass+Turn with 2nd corners & 1s turn right about to face 1st crnr, repeat with 1st crnr & end turning right about to 1L facing up & 1M down
- 17-24** 1s dance RH across (Lady with 2s & Man with 3s), 2s & 3s chase clockwise 1/2 way (1s follow couples & end in middle)
- 25-32** 1s dance LH across (Man with 3s at top & Lady with 2s) & all chase anticlockwise 1/2 way to end 2 1 3  
Second time: 1s+4s change places LH on sides as new 1s begin

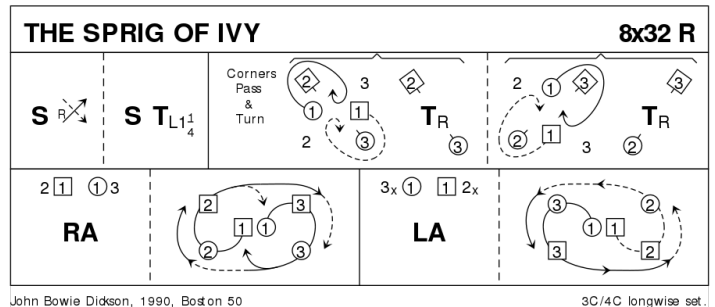

## 8 A CAPITAL JIG J32 · 3/4L

Tine E MacKay: Magazine Dances 2005-2009 · Crib: MiniCribs · Diagram: Keith Rose's Diagrams

- 1-8** 1s+2s Set & Rotate & end 1s facing up, 2s down:  
Set, rotate singly & dance on 1 place clockwise, change places RH on sides & dance on 1 place to own sides (1s in 2nd place facing up)
- 9-16** 1s dance reels of 3 on own sides (RSh to 2s)
- 17-24** 1s set & turn 3/4 RH to face own sides, 1s dance LH across (1L with 2s, 1M with 3s) to end 2nd place opposite sides
- 25-32** 1s set & turn 3/4 RH to face opposite sides, 1s dance LH across (1M with 2s, 1L with 3s) ending 2nd place own sides

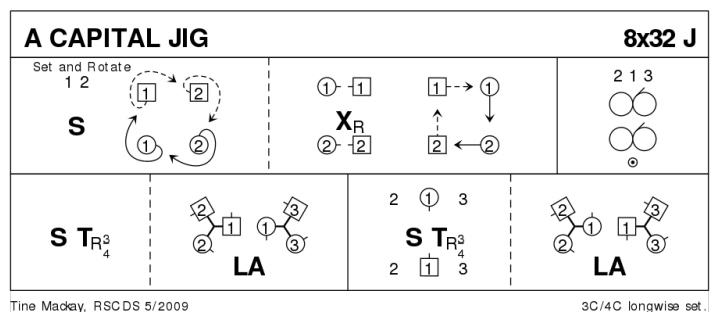

## 9 SAINT COLUMBA'S STRATHSPEY S32 · 5/5L

Vicky Sproule & Sadie L. Gillan: *Saint Columba's Strathspey (Leaflet)* · Crib: *MiniCribs* · Diagram: Keith Rose's Diagrams

- 1-8** 2s+4s dance RH across, 2s dance up **while** 4s dance down, 2s & 4s casting round ends on own sides to face 1st corners
- 9-16** 2s+4s Pass+Turn with 1st corners, pass partner LSh & Pass+Turn with 2nd corners & into centre facing partner (L facing down M up)
- 17-24** 2s+4s dance reel of 4 ending in original places on sides
- 25-32** 2s & 4s set & cast down 1 place **while** 3s & 5s set & dance up 1 place, 1s & 2s turn RH & cast down 1 place. 3 1 5 2 4

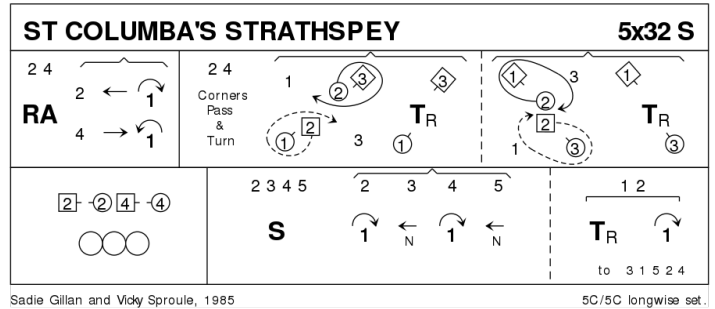

Sadie Gillan and Vicky Sproule, 1985

5C/5C longwise set.

## 10 SCOTT MEIKLE R32 · 4/4L

Alice McLean: *RSCDS XLVI 3* · Crib: *MiniCribs* · Diagram: Keith Rose's Diagrams

- 1-8** 1s cross RH & cast to 2nd place, 1s dance 1/2 Fig of 8 round 2s
- 9-16** 1s+3s dance RH across, LH back
- 17-24** 1L followed by 3L dance Tandem reel of 3 across with 2s (LSh to 2M) & 1s end 3rd pl **while** 3M followed by 1M dance reel of 3 with 4s (LSh to 4L) & 3s end in 2nd pl 2 3 1 4
- 25-32** 1s+4s dance 1/2 R&L, turn partners RH 1.1/2 times 2 3 4 1

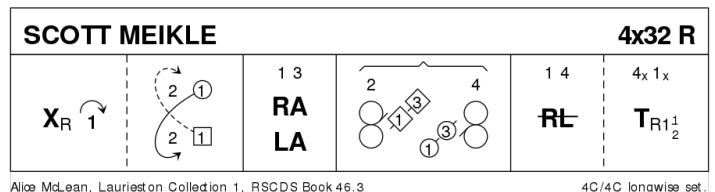

Alice McLean, Laurieston Collection 1, RSCDS Book 46.3

4C/4C longwise set.

## 11 THE JUBILEE JIG J32 · 3/4L

RSCDS: *The Leaflet Dances with Music* · Crib: *MiniCribs* · Diagram: Keith Rose's Diagrams

- 1-8** 1M casts to 2nd place, sets to 3L, turns RH & dances back to 2nd place on own side
- 9-16** 1L casts to 2nd place, sets to 3M, turns LH & dances back to 2nd place
- 17-24** 1L with 2s & 1M with 3s dance RH across, 1s end in centre LH joined, 1s set in centre & dance out to 2nd place on opposite sides
- 25-32** 1M with 2s & 1L with 3s dance RH across, 1s end in centre LH joined, 1s set in centre & dance out to 2nd place on own sides

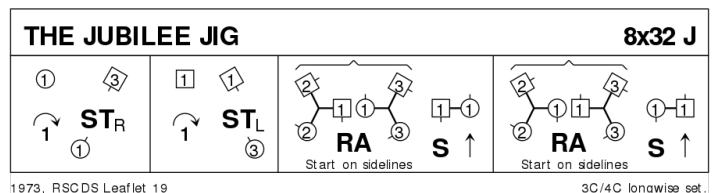

1973, RSCDS Leaflet 19

3C/4C longwise set.

## 12 ORPINGTON CALEDONIANS

R32 · 3/4L

John Brenchley: RSCDS XLIX 2 · Crib: MiniCrib · Diagram: Keith Rose's Diagrams

- 1-8** 1s set, 1L casts & followed by 1M, dances across to 2M's place facing out (2s step up 5-6). 1L+3M also 1M+3L 1/2 turn LH & Men face out
- 9-16** 3s+1s dance Ladies' Chain, 1M finishes facing out
- 17-24** 1M followed by 1L casts up, dances across to 2M place (3s step down 19-20). 2s+1s dance RH across. 1M & 2L face out
- 25-32** 2s+1s+3s dance reels of 3 on sides (1s+3s pass LSh to start)

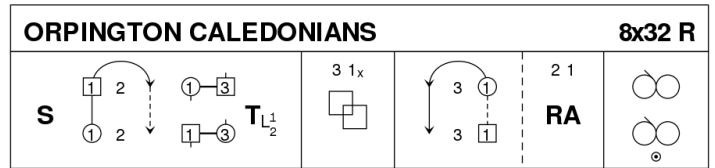

John Brenchley, 1987, RSCDS Book 49.2

3C/4C longwise set.

## 13 JEAN MARTIN OF ABERDEEN

S32 · 3/3L

Muriel A Johnstone: Magazine Dances 2005-2009 · Crib: MiniCrib · Diagram: Keith Rose's Diagrams

- 1-8** 1s turn RH & cast 1 pl, all circle 6H round 3/4 way to left & end in lines of 3 across (Ladies face down & Men up)
- 9-16** All set & change places with partner RH, all circle 6H round 3/4 way to left & end in middle facing up. 3 1 2
- 17-24** All dance Allemande. 2 1 3
- 25-32** 1s+3s (bottom 2 couples) dance the Bourrel to end 2 3 1 :  
1M+3L set advg, 3/4 turn 2H & twirl to end BtoB (up/down middle L facing up & M down) **while** 1L+3M chase anticl'wise 1/2 way to face ptrnr  
1s+3s set to partners & turn 2H to own sides having changed places

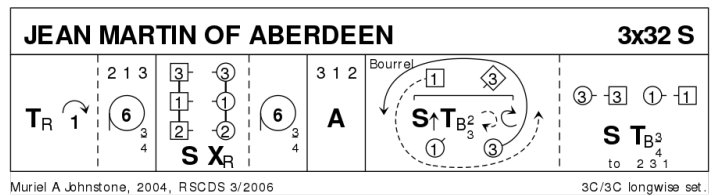

Muriel A Johnstone, 2004, RSCDS 3/2006

3C/3C longwise set.

## 14 SWIRLING LEAVES

J32 · 3/4L

Gary Lindsey: Eight by Thirty-Two · Crib: E-cribs

- 1-** 1c set | cross RH ; cast (2c up) | turn LH to face 1c nr
- 9-** 1c+1cnrs »Pass, Turn, Face and Cast away« [pass cnr Rsh, cnrs turn RH 1/2 and face | cnr cast R to diagonally opposite place as 1c returns to centre], 1c pass Rsh ; 1c+2cnrs »Pass, Turn and Cast away« to (3x,1x,2x)
- 17-** 1/2 Reels3 across, 1c giving Rsh to 4c nr pos (3,1,2) ; 1/2 Reels3 on the sides, 1c Lsh to 3c nr pos (2,1,3)
- 25-** Circle6 and back

## 15 WE'VE NAE ELECTRIC R32 · 5/5L

Gary Coull: Jubilee Book 1929-2004 [Banffshire] · Crib: MiniCrib's · Diagram: Keith Rose's Diagrams

- 1-8** 1s+3s cross down RH into double triangle position & set, dance round 1st corner into a line up/down middle facing partner
- 9-16** 1s+3s dance reel of 4 **while** 2s+4s+5s dance reels of 3 on sides (4M in & up, 4L in & down to start)
- 17-24** 1s & 3s 1/2 turn partner RH, dance RSh round 2nd corner & turn partner RH 1.1/2 times to 2nd/4th place own sides
- 25-32** 1s+4s also 3s+5s Set+Link & all turn RH to end 2 4 1 5 3

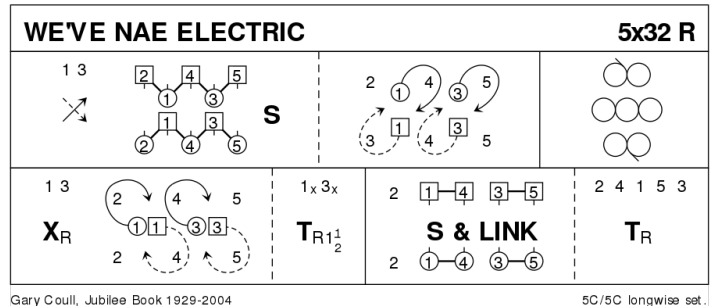

## 16 THE BELLE OF BON ACCORD S32 · 4/4L

John Drewry: Deeside Book Part 2 · Crib: MiniCrib's · Diagram: Keith Rose's Diagrams

- 1-8** 1L & 3L cross down 1 pl & cast up on opp side into centre as 1M & 3M dance across & cast down into centre, 1s+2s & 3s+4s dance RH across
- 9-16** 1s & 3s dance reel of 4 up & down centre of dance
- 17-24** 1s & 3s 3/4 turn RH to face up **while** 2s & 4s dance up on sides & turn in to face down & all set, all circle 4H round to left & end on sides
- 25-32** 1s & 3s lead up between 2s/4s crossing over & cast down 1 place, 1s & 3s turn 2H & 1s dance down to 4th place as 3s cast up on own sides to 2nd pl

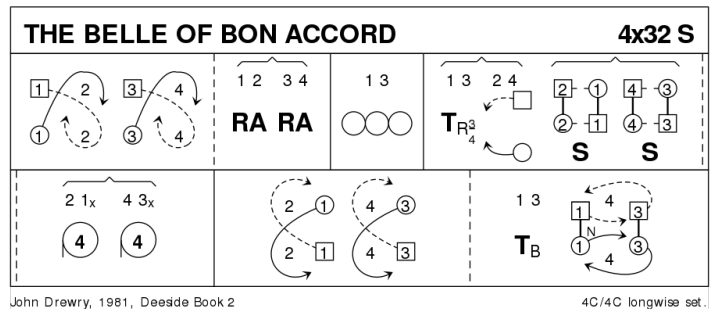

## 17 FINDLATER CASTLE R32 · 3/4L

Bill Forbes: Jubilee Book 1929-2004 [Banffshire] · Crib: MiniCrib's · Diagram: Keith Rose's Diagrams

- 1-8** 1s cross down RH to 2nd place & Bal-in-Line with 1st+2nd corners, turn 1st corner RH, partner LH to 2nd place own sides facing out
- 9-16** 1s dance reels of 3 on own sides (Man down, Lady up - 1M+3M & 1L+2L pass LSh to start). End 1L at bottom facing up, 1M at top facing down, to cross LH ready for...
- 17-24** 1s dance RH across (1L with 2s, 1M with 3s) into 2nd place own sides & 2s+1s+3s chase clockwise 1/2 way
- 25-32** All Set+Link for 3 twice

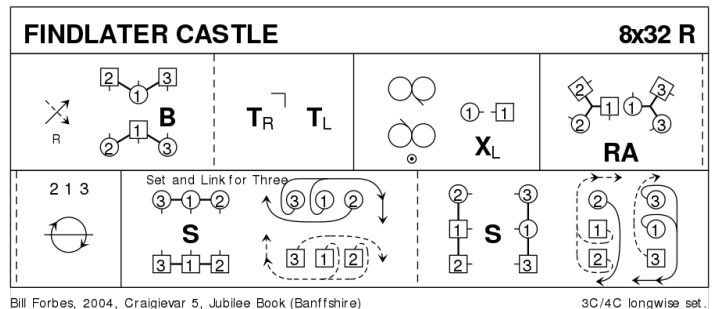

## 18 PELORUS JACK J32 · 3/4L

Barry Skelton: RSCDS XLI 1 · Crib: MiniCribbs · Diagram: Keith Rose's Diagrams

- 1-8** 1s cross RH & cast 1 place, dance RH across with 3s. 1s end with Man facing his 1st corner with his partner behind him
- 9-16** 1s dance Alternating Tandem 1/2 reel of 3 with 1st corners to face Man's 2nd corner, 1s dance Alternating Tandem 1/2 reel of 3 with 2nd corners
- 17-24** 1s dance Alternating Tandem 1/2 reels of 3 with Ladies' 1st corner (pstin), 1s dance Alternating Tandem 1/2 reel with Ladies' 2nd corner (pstin)
- 25-32** 1M followed by partner dance into LH across with 2s, 1s retain LH & 1/2 turn to own sides & 2s+1s+3s set

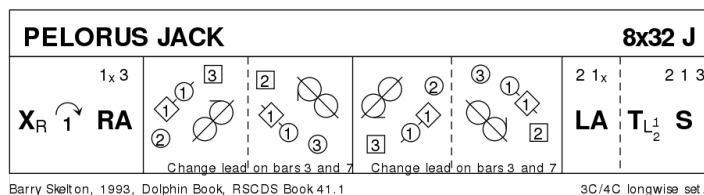

## 19 CITY OF BELFAST S32 · 3/3L

Lucy Mulholland: RSCDS XLVIII 6 · Crib: MiniCribbs · Diagram: Keith Rose's Diagrams

- 1-8** 1s dance 1/2 Fig of 8 round 2s, 1L+2M turn RH 1.1/4 times **while** 1M+2L turn LH 1.1/4 times & 1s end BtoB facing opp sides
- 9-16** 1s+2s dance reel of 4 across & 2s end in 1st places **while** 1s pass LSh to face 1st corners
- 17-24** 1s set to 1st corner & 2nd corner ending (turning to right) between corners, all set & 1s cross RH
- 25-32** 1s+3s dance Espagnole:  
**25-26** 1s+3s cross (Ladies lead across RH passing between Men) with Ladies changing places RH  
**27-28** 1s+3s cross back (Men lead across RH between Ladies) with Men changing places RH  
**29-32** 3s turn RH as 1s turn LH to end 2 3 1

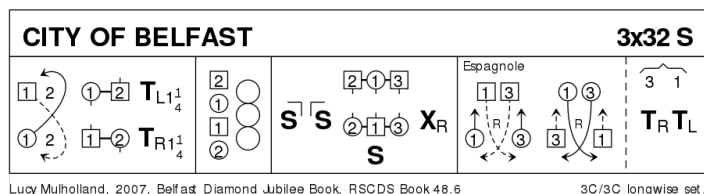

## 20 THE FIREWORKS REEL R32 · 3/4L

Anselm Lingnau: RSCDS XLVIII 11 · Crib: MiniCribbs · Diagram: Keith Rose's Diagrams

- 1-8** 1s cross RH & cast 1 place, 1s dance 1/2 figures of 8 (1L round 2s, 1M round 3s) & end facing 1st corners
- 9-12** 1s set moving out between corners (as in Hello-Goodbye setting) & 1s turn LH to face 1st corners
- 13-16** 1s dance 1/2 diagonal reel of 4 with 1st corners & end facing 2nd corners
- 17-24** 1s repeat bars 9-16 with 2nd corners & end 2nd place opposite sides (3)(1)(2)
- 25-32** 1s dance 1/2 reel of 3 on opposite sides (1M in & down, 1L in & up), 1s dance 1/2 reel of 3 across (1M with 2s & 1L with 3s)

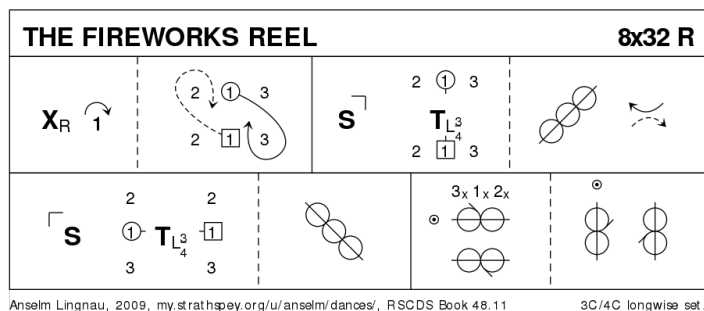

## 21 HOGMANAY REBELS R40 · 2RR

Judith Kowalczyk: *Potters Pairs · Crib: MiniCribs*

Round the Room, 2 facing 2

- 1-8 All Adv (2) Ret (2) Couples facing clockwise dance between facing couple, turning them with NH back to place
- 9-16 Couples facing clockwise join 2H & slip step between facing couple (4 bars) & slip step back to place
- 17-32 Repeat bars 1-16 with anticlockwise couples as dancing couple
- 33-40 All set, pass opp person LSh to meet new couples & all circle 4H round to Left

## 22 NEW YEAR JIG J32 · 3/4L

Maureen Robson: *RSCDS LI 8 · Crib: MiniCribs · Diagram: Keith Rose's Diagrams*

- 1-8 1s dance Fig 8 on own sides (pass 2s RSh to start). 1L ends facing out
- 9-16 Reels of 3 on sides (1s+2s pass RSh to start). 1L end facing out
- 17-24 1L followed by 1M dances behind 2L, up between 2s, behind 2M, across set to 2nd place own side (2s step up 23-24)
- 25-32 1s+3s dance RH across. 2s+1s dance LH across. 1L finishes facing out, ready to start again

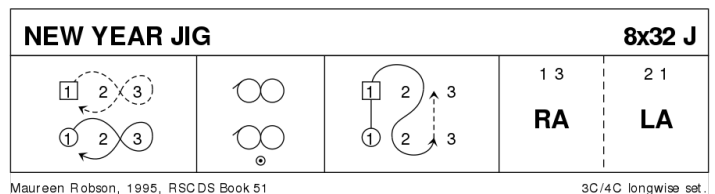

## 23 THE FINAL REEL R32 · 3/4L

Ian Barbour · *Crib: MiniCribs · Diagram: Keith Rose's Diagrams*

- 1-8 1s cross RH, cast 1 place & turn LH 1.1/4 times to end 1M between 2s & 1L between 3s
- 9-16 2s+1s+3s Set+Link for 3 twice 1s end facing 1st corners pstns
- 17-24 1s dance 1/2 reel with 1st corners & 1/2 reel with 2nd corners, 1s ending in 2nd place own sides
- 25-32 2s+1s+3s circle 6H round & back

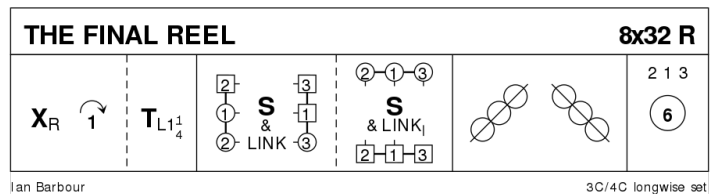

## 24 LOCHINDORB STRATHSPEY S32 · 3/3L

Anne Hutchison: *An Aberdeen Collection · Crib: MiniCribs · Diagram: Keith Rose's Diagrams*

- 1-8 1s & 3s petronella turn & set, turn partners 1.1/4 to places
- 9-16 2s petronella turn & set, change places LH & dance LSh round 3rd corners to places
- 17-24 All dance Grand Chain
- 25-32 All set, circle 6H round to left 1/2 way, set & 3s+2s dance 1/2 RH across **while** 1s cross RH

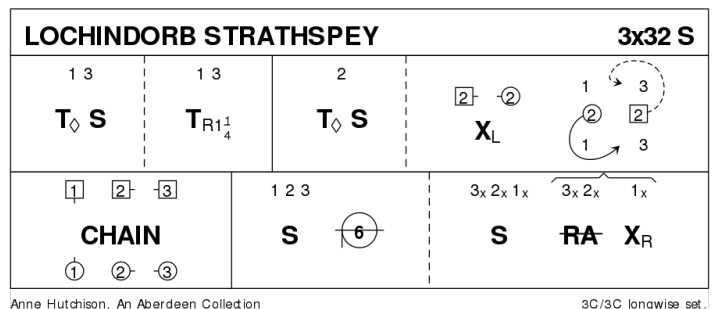



## 25 MARY ERSKINE R32 · 3/4L

Roy Goldring: *A Second Book of Graded Scottish Country Dances* · Crib: *MiniCribs* · Diagram: *Keith Rose's Diagrams*

- 1-8** 1s+2s turn on sides 1.1/2 times (Men RH & Ladies LH), 1s cast down behind 3s, meet & dance up to 2nd place facing own sides ready for -
- 9-16** 1s dance Double Triangles & end by turning right about to face each other (remaining in middle)
- 17-24** 1s slip step down centre & back
- 25-32** 1L dances LH across on Men's side as 1M dances RH across on Ladies side & dance 1/2 Fig of 8 round 2s

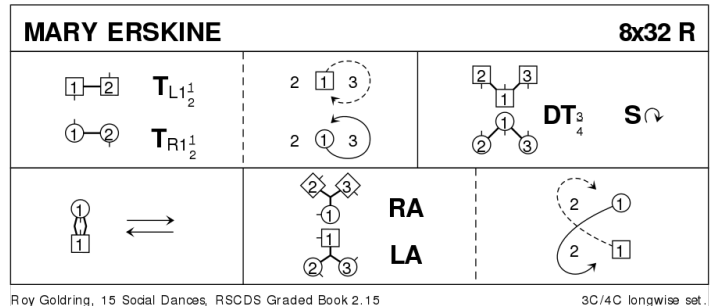

## 26 THE KELLOHOLM JIG J32 · 3/4L

Peter Hyssett: *The Leaflet Dances with Music* · Crib: *MiniCribs* · Diagram: *Keith Rose's Diagrams*

- 1-8** 1s set & cast 1 place, set on side lines to 1st corners & change places with them RH
- 9-16** 1L+3L also 2M+1M set to each other on sides & change places LH, 1s turn RH 1.1/2 times to 2nd place on own sides
- 17-24** 1s set on side lines to 2nd corners & change places with them RH, 1M+3M also 2L+1L set to each other on sides & change places LH
- 25-32** 3s+1s+2s Adv+Ret, circle 6H round 1/2 way to left

