

St Andrews Celebration, Craigiebuckler - Sat 1 Dec 6:45 for 7:00

1 THE WESTMINSTER REEL R32 · 2/4L

Jeremy Hill: RSCDS XLV 1 · Crib: MiniCribs · Diagram: Keith Rose's Diagrams

- 1-8** 1M+2L turn RH, 1L+2M turn RH 1.1/2 times end facing partner ready for diagonal reel of 4
- 9-16** 1s+2s dance diagonal reel of 4
- 17-24** 1s+2s Set & Rotate :
Set facing diagonally in, rotate singly & dance on 1 place clockwise, change places RH on sides & dance on 1 place to own sides (1s in 2nd pl)
- 25-32** 2s+1s dance R&L

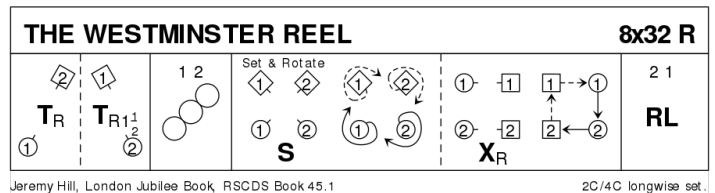

2 NEWBURGH JIG J32 · 3/4L

Allana Creighton: RSCDS XLVIII 1 · Crib: MiniCribs · Diagram: Keith Rose's Diagrams

- 1-8** 1s+2s+3s dance 6H round and back
- 9-16** 1s set, cast off (2s step up), turn LH to face 1st corners
- 17-24** 1s+ 1st corners set, 1s dance round each other by right to face 2nd corners. 1s + 2nd corners repeat, 1s finish in middle facing own sides, 1M below 1L
- 25-32** 1L+2s also 1M+3s dance LH across. 1s finish in 2nd place opposite sides. 2s+1s+3s set, 1s cross RH to 2nd place own sides

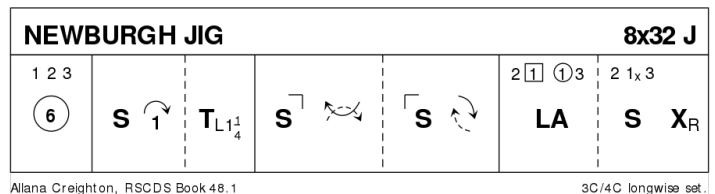

3 THE BLUE BUTTERFLY S32 · 3/3L

Chris Brooks · Crib: MiniCribbs · Diagram: Keith Rose's Diagrams

- 1-4** 1s cross down RH to 2nd place opposite sides & change place with 3s (RH Ladies' side, LH Men's side)
- 5-8** 1s dance up & turn 2s (RH Ladies' side, LH Men's side) to end 2nd place opposite side
- 9-16** 1s dance RSh reels of 3 across (1L with 2s, 1M with 3s)
- 17-24** 1s dance RH across (1L with 3s, 1M with 2s), 1s dance 1/2 Figs of 8 to end 2nd place own sides (1L round 2s, 1M round 3s) 2 1 3
- 25-32** 1s+3s dance Espagnole to end 2 3 1 :
25-26 1s+3s cross (Ladies lead across RH passing between Men) with Ladies changing places RH
27-28 1s+3s cross back (Men lead across RH between Ladies) with Men changing places RH
29-32 3s turn RH as 1s turn LH to 3rd places

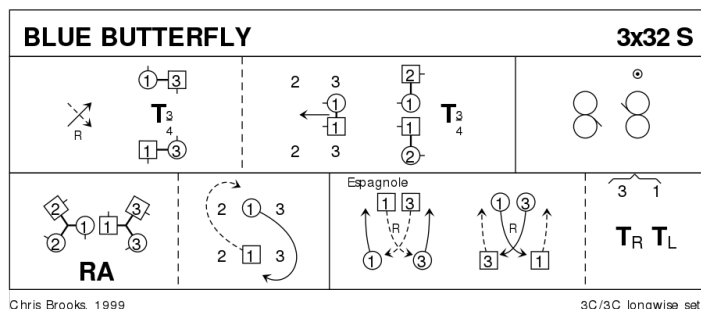

4 SAINT ANDREW'S DAY R32 · 3/4L

RSCDS XXIV 5 · Crib: MiniCribbs · Diagram: Keith Rose's Diagrams

- 1-8** 1s, followed by 2s, cast on own sides below 3s, meet & lead up to top, 1s cast, pass LSh to face 1st corners **while** 2s dance up to top
- 9-16** 1s dance round 1st corners (RSh), pass LSh in centre, dance round 3rd corner RSh, pass partner LSh to face 2nd corners
- 17-24** 1s repeat above Fig round 2nd corners & 4th corners to end BtoB facing corners (1M facing Ladies' side, 1L facing Men's side)
- 25-32** 1M with 2L+3L also 1L with 2M+3M circle 3H round to left (4 bars), & dance 1/2 Double Triangles & petronella turn to end in 2nd place own side

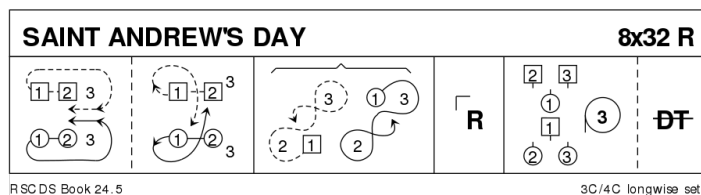

5 WELCOME TO AYR J32 · 3/4L

Jill Hendricksen/Kathy Stewart: RSCDS XLVII 8 · Crib: MiniCribbs · Diagram: Keith Rose's Diagrams

- 1-8** 1s+2s dance double Fig of 8 (1s cross down to start)
- 9-16** 1s turn 2s on sides (Men RH, Ladies LH) & 1s dance down to turn 3s on sides (Men RH, Ladies LH) & 1s end facing 1st corners
- 17-24** 1s dance 1/2 reel of 4 with corners & pass RSh to face 2nd corner, 1s dance 1/2 reel of 4 with crnrs & 1s end in middle LSh to LSh facing own sides
- 25-32** 1M+3s (at top) also 1L+2s dance RH across (1s end in 2nd place opposite sides), all chase clockwise 1/2 way to own sides

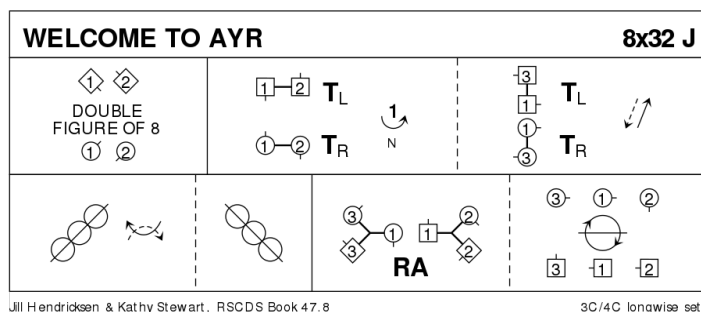

6 TARTAN RAINBOW S32 · 3/3L

Sue Petyt: Tartan Rainbow · Crib: MiniCrib · Diagram: Keith Rose's Diagrams

- 1-8** 2s set, 2M casts up & 2L down to positions above/below 1s/3rd couples & dance RH across (2M with 1s & 2L with 3s)
- 9-16** 2s set advancing down/up & turn 2H to end in centre 2M facing up & 2L facing down & dance LH across (2M with 1s & 2L with 3s)
- 17-24** All dance the Knot ending 3 2 1
- 25-32** 2s cross RH, cast down to bottom & dance 1/2 Fig of 8 round couple above (1s). 3 1 2

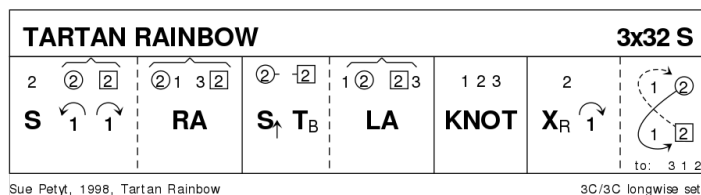

7 TRIP TO TIMBER RIDGE R32 · 3/4L

Linda Henderson: RSCDS LII 12 · Crib: MiniCrib · Diagram: Keith Rose's Diagrams

- 1-8** 1s turn RH, cast (2s step up) then 1L+2s & 1M+3s dance RH across. 1s end facing 1st corners
- 9-16** 1s dance Corner Pass+Turn with 1st corners, pass RSh & repeat with 2nd corners. 1s pull back RSh to end BtoB in centre facing opp sides
- 17-24** 2s+1s+3s dance Double Triangles. Bars 23-24 1s petronella turn to 2nd place own sides
- 25-32** 2s+1s+3s circle 6H round and back

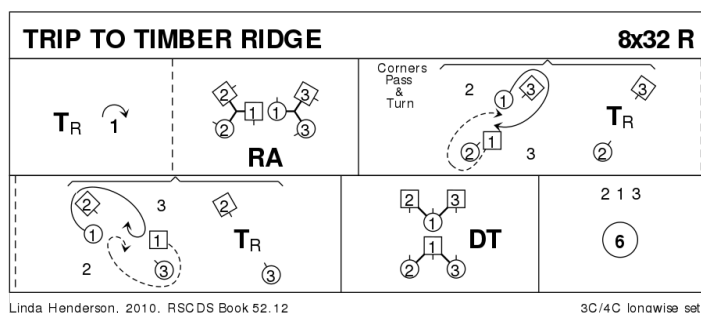

8 JOHN CASS J32 · 5/5L

Peter Avery: RSCDS XLIX 10 · Crib: MiniCrib · Diagram: Keith Rose's Diagrams

- 1-8** 1s lead down (2s+3s step up 3-4), lead up to 3rd place & turn RH to face 3M with 1L following 1M
- 9-16** 1s, 3M+2M, 4L+5L all in tandem, dance alternating tandem reel on diagonal (1s pass 3M+2M RSh). 1s end facing 4M, 1L following 1M
- 17-24** 1s, 4M+5M, 2L+3L all in tandem, repeat 9-16 (1s pass 4M+5M LSh) 1s end in middle, 3rd place facing down NHJ (1L on Left of 1M)
- 25-32** 1s dance down between 4s, cast behind 5s (4s+5s step up 27-28), 1s pivot turn (R elbow grip) & finish in 5th place 2 3 4 5 1

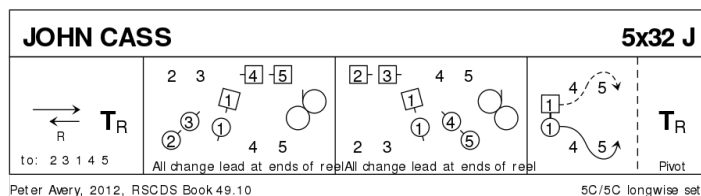

9 BY DUNDONALD S32 · 3/3L

Ian Barbour: Repeat Prescription (PDF) · Crib: MiniCribs · Diagram: Keith Rose's Diagrams

- 1-8** 1s+2s dance the Tourbillon:
 1s & 2s turn partners 2H 1/2 way, 1M & 2L lead partners on 1 place clockwise to end 1s on Ladies' side & 2s on Men's side, 1s set to 2s
 1s & 2s 1/2 turn partners 2H, 1L & 2M lead partners on 1 place to end 2s in 1st pl & 1s in 2nd pl & 2s+1s cross RH to own sides
- 9-16** 2s+1s+3s dance reels of 3 on sides (1s give RSh to person on right) & end with 1M facing up between 3s, 1L between 2s facing down
- 17-24** 1s set, turn RH, 1L dances up between 2s **while** 1M dances down between 3s & cast to 2nd place on own side
- 25-32** 2s+1s+3s dance Allemande

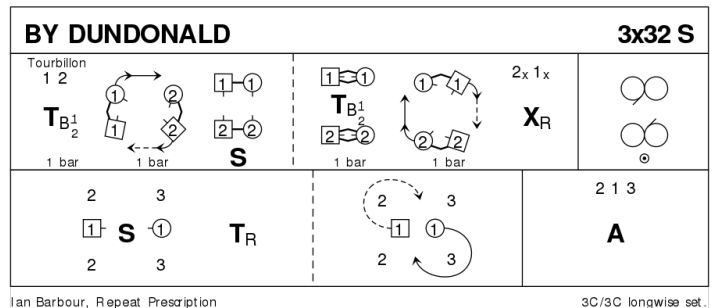

10 MACDONALD OF KEPPOCH M128 · 4S

Chris Ronald: RSCDS XLIX 11 · Crib: MiniCribs · Diagram: Keith Rose's Diagrams

- 1-8** 1s+3s dance 6 bars R&L (Men polite turns) to finish in centre B-to-B with partner facing side couples (1L+2L, 1M+4M, 3L+4L, 3M+2M). All set
- 9-16** Reels of 4 across. Finish in line up/down with Ladies (in middle) facing, 1M facing down, 3M facing up
- 17-24** Reel of 4 (1L+3L pass RSh) All pass LSh at ends, RSh in middle. Finish in original places facing partners
- 25-32** All set, all turn partner RH 1.1/4 into promenade hold & dance 1 place anticlockwise.

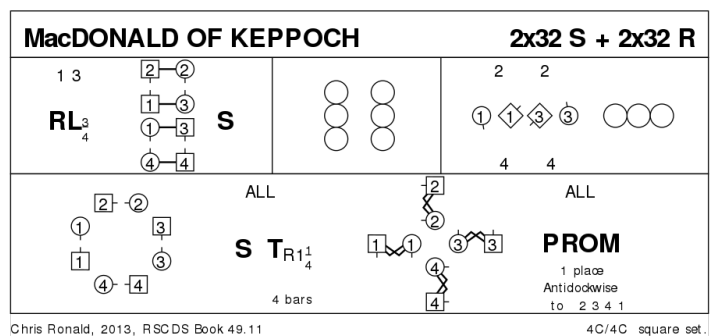

Repeat from new positions in Strathspey then twice in Reel time back to original places

11 FESTIVAL FLING R32 · 3/4L

Lily Davison: RSCDS XLIV 7 · Crib: MiniCribs · Diagram: Keith Rose's Diagrams

- 1-8** 1s set, cross RH, cast 2 places & dance up to face 1st corners
- 9-12** 1s set to 1st corner & change places RH with 1st corner persons passing LSh to face 2nd corners (M facing M & L facing L)
- 13-16** Original 1st corner persons set to 2nd corners & change places RH with 2nd corners passing LSh to face 1st corner (M facing M & L facing L)
- 17-20** Original 2nd corner persons set to 1st corners (1s), change places RH & 1s end facing opposite sides as for double triangles
- 21-24** All set, corner persons chase 1 place clockwise **while** 1s PdB round each other to face down (Man with partner on left)
- 25-32** 1s dance down between 3s, cast up to 2nd place, dance up between 2s & cast to 2nd place

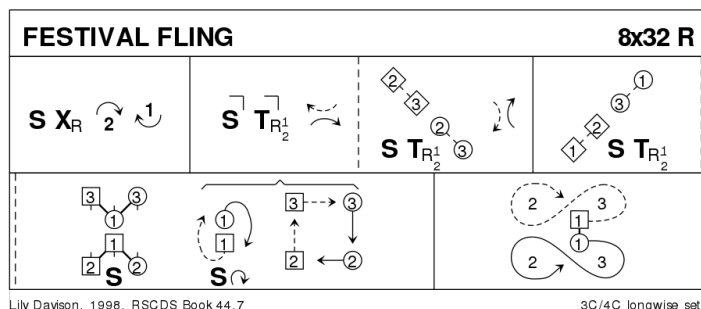

12 RODNEY'S RANT J32 · 3/4L

Ann Dix: QE Diamond Jubilee Dances · Crib: MiniCribs · Diagram: Keith Rose's Diagrams

- 1-8** 1s set & cast 1 place, dance down between 3s & cast up to 2nd places
- 9-16** 1s dance Diag R&L. (3)1(2)
- 17-24** All Set+Link for 3 twice. 2(1)3
- 25-32** 1L dances 1/2 Fig of 8 with 2s as 1M dances 1/2 Fig of 8 with 3s, all turn partners RH

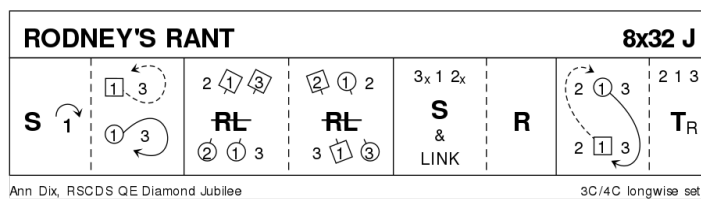

13 AUTUMN IN APPIN S32 - 4/4L

John Drewry: RSCDS XXXI 5 · Crib: MiniCribbs · Diagram: Keith Rose's Diagrams

3s & 4s start on opp. sides

- 1-8** 2s+3s Petronella turn into centre & set to partner (Men BtoB), 2s+3s 3/4 turn partner RH & dance RH across 1/2 way to change places & end with other partner in prom hold (2M+3L facing Men's side & 3M+2L facing Ladies' side)
- 9-10** 1s & 4s Petronella turn into centre **while** 2M+3L dance out & up on Men's side & 3M+2L dance out & down on Ladies' side
- 11-12** 1s & 4s set to partner **while** 2M+3L/3M+2L cross to other side passing between 'gates' (1s & 4s)
- 13-14** 1s & 4s 1/2 turn RH into prom hold (1s facing Ladies' side & 4s facing Men's side) **while** 2M+3L/3M+2L dance down/up sides
- 15-16** All Promenade cl'wise 1 pl to end in square set (1s on Ladies' side facing 4s on Men's side, 2M+3L in 4th pl face up as 3M+2L in 1st pl face down)
- 17-24** 1s+4s dance 1/2 Ladies' Chain , 2s+3s dance 1/2 Men's (2s & 3s ending with Lady on Mans left)
- 25-32** All set in square set & circle 8H round to left, dance into centre, turn right & spiral out to own side lines ending 2 4 (1)(3)

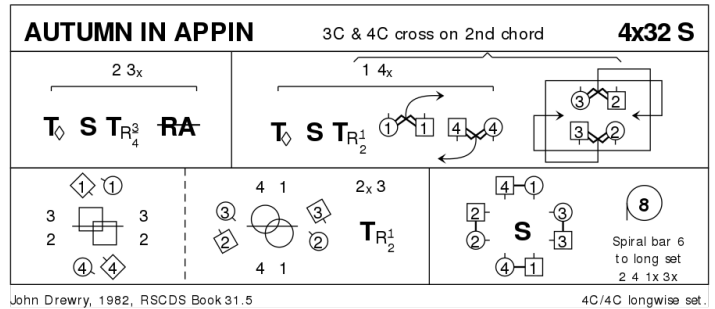

14 JOHNNIE'S WELCOME HAME R40 - 3/4L

Neil M Grant: RSCDS XXXII 1 · Crib: MiniCribbs · Diagram: Keith Rose's Diagrams

- 1-8** 1s+2s+3s set, cross RH, set & cross back RH
- 9-20** 1s+2s+3s dance 3 couple R&L
- 21-24** 1s cast 1 place on own side to end in diagonal line (RH with 1st corners & LH to partner)
- 25-32** 2s+1s+3s dance the Spoke : Bal-in-Line with 1st corners, then with 2nd corners, then with 3rd corners & 4th crnrns
- 33-40** 1s dance 1/2 Fig of 8 round 1st corners LSh to meet in the centre & turn 1.1/2 times LH to 2nd place own sides

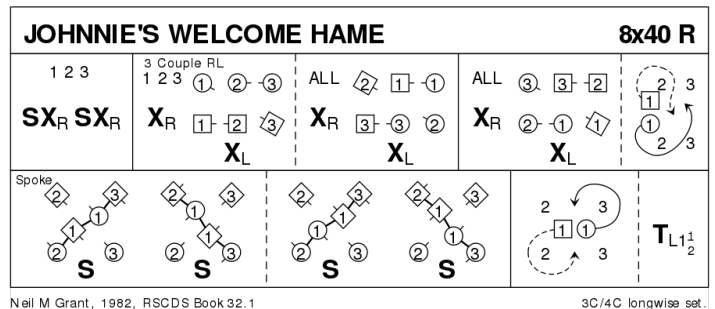

15 THE CRANBERRY TART J32 · 3/4L

Terry Glasspool: Dances from the Seven Year Itch · Crib: MiniCrib · Diagram: Keith Rose's Diagrams

- 1-8** 1M sets & casts 1 place, sets & petronella turns between 3s facing up **while** 1L stands for 2 bars then sets, casts 1 place & sets
- 9-16** 1M sets in line with 3s & all 3 Adv+Ret then 1M advances to partner **while** 1L petronella turns between 2s & sets in line with 2s then all 3 Adv+Ret
- 17-24** 1L followed by partner dances reel of 3 across with 2s (RSh to 2L) to end in 2nd place own sides
- 25-32** 1s dance RSh reels of 3 on sides giving RSh to 3s

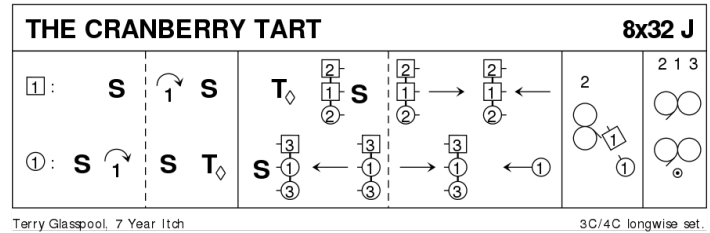

16 MEMORIES OF MARY ANN S32 · 3/3L

Pam Stephens: RSCDS XLVII 7 · Crib: MiniCrib · Diagram: Keith Rose's Diagrams

- 1-8** 1s set & cast 1 place, 1s dance 1/2 reels of 3 across passing 1st corners LSh to start & 1s ending 2nd place opposite sides
- 9-16** All Set+Link, 1s turn LH to face 1st corners (position)
- 17-24** 1s dance 1/2 RSh diagonal reel of 4 & end facing 2nd corners (pstn), dance 1/2 reel of 4 with 2nd corners & end 2nd place own sides
- 25-32** 1s+3s dance the Knot

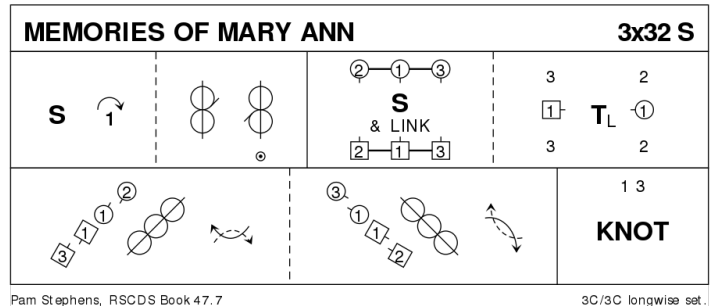

17 THE COUNTESS OF DUNMORE'S REEL R32 · 3/4L

Deirdre MacCuish Bark: RSCDS XLIX 12 · Crib: MiniCrib · Diagram: Keith Rose's Diagrams

- 1-8** 1s set, dance down below 3s, cast up to 2nd place & set advancing to face 1st corners (2s step up 3-4)
- 9-16** 1s turn 1st corners RH, pass RSh, turn 2nd corners RH, pass RSh to 2nd place own side facing out (corners dance 4 bars)
- 17-24** Promenade (Chaperoned) Chain progression:
17-18 1M casts up, 1L casts down as 2s+3s turn 3/4 RH into line up/down set
19-22 1M+2L & 1L+3M, in prom hold dance clockwise to opp end of line as 2M+3L (in middle) turn 1.1/2 LH
23-24 1s dance clockwise to 2nd place own side as 3s+2s turn partners 3/4 RH to own sides. All face clockwise 3 1 2
- 25-32** 3s+1s+2s dance clockwise 1/2 round set. All set, cross RH to own sides. 2 1 3

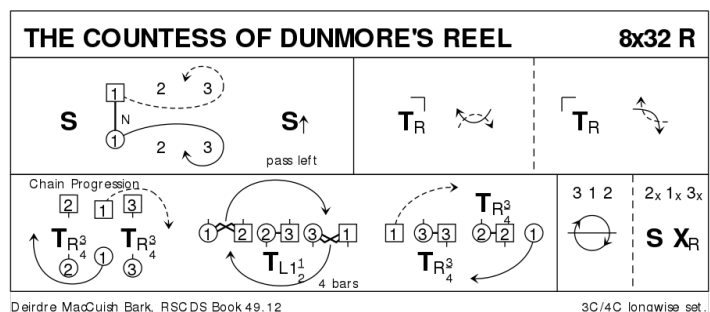

18 MACLEOD'S FANCY J32 · 4/4L

John Drewry: RSCDS XXXIII 3 · Crib: MiniCrib · Diagram: Keith Rose's Diagrams

- 1-8** 1s+4s set diagonally, 1M+4L 3/4 turn RH & cast up/down own side back to place **while** 1L+4M cast down/up own side & 3/4 turn RH back to place
- 9-16** All dance reels of 4 on sides, ending as at start of reel
- 17-24** 2s & 3s turn 1s & 4s RH into a St Andrew's Cross, all set & turn cmrns to end 1s in 3rd pl & 4s in 2nd pl on own sides having passed other cmr RSh
- 25-32** 1s & 4s set & cross over (Ladies dancing between Men) & dance 1/2 Fig of 8 round end couples to 3rd/2nd places (giving RH at top, LH at bottom)

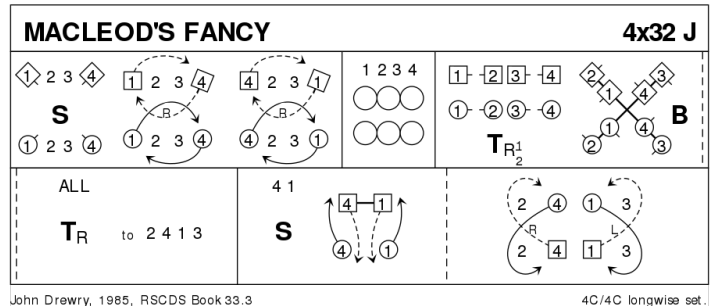

19 SPINKIE DEN S32 · 3/3L

Nan Lawson: Glasgow Branch A Collection of Dances for the 75th Anniversary 1923-1998 · Crib: MiniCrib

- 1-8** 1L+2M change places RH, 1s+2s circle 4H round to left 1/2 way, 1M+2L change places RH & 1s+2s circle 4H round to left 1/2 way
- 9-16** 1s followed by 2s lead down & 2s followed by 1s lead back Men crossing partner in front of them to own sides
- 17-24** 1s set, dance up between 2s, cast, dance down between 3s & cast up to 2nd places
- 25-32** 1s+3s Set & Rotate :
Set, rotate singly & dance on 1 place clockwise, change places RH on sides & dance on 1 place to own sides (1s in 2nd pl)

20 LATE IN THE DAY R40 · 3/4L

John Bowie Dickson: Dunedin Dances Book 5 · Crib: MiniCrib · Diagram: Keith Rose's Diagrams

- 1-8** 1s set & cross down RH, set & 3/4 turn LH to face 1st corners
- 9-16** 1s dance 1/2 diagonal reel with 1st corners, pass RSh & dance Pass+Turn with 2nd corners
- 17-24** 1s dance Pass+Turn with 3rd corner (pstns) & 1/2 diagonal reel with 4th corner (pstns)
- 25-32** 1s dance RH across (1L with 3s at top & 1M with 2s) end in 2nd place opposite sides & chase clockwise 1/2 way
- 33-40** 2s+1s+3s circle 6H round & back

