

Dufftown 4th October 2019

1 HEDWIG'S REEL R32 · 3/4L

Stella Phillips: A Second Book of Graded Scottish Country Dances · Crib: MiniCribS · Diagram: Keith Rose's Diagrams

- 1-8 1s dance Figs of 8 on own sides (RSh to 2s)
- 9-16 1s turn RH & cast 1 place, 1s turn LH into 2nd place facing down
- 17-24 2s+1s+3s dance Grand Chain
- 25-32 2s+1s+3s Adv+Ret, 2s+1s+3s turn RH

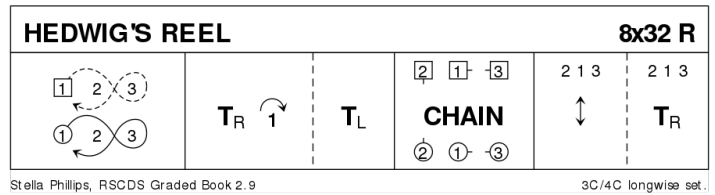

2 THE LANCASTRIAN WANDERER J32 · 3/4L

Ian Barbour: Magic Medicine · Crib: MiniCribS · Diagram: Keith Rose's Diagrams

- 1-8 1s+2s set, dance RH across & 1s cast to face 1st corners
- 9-16 1s turn 1st corner RH, pass partner RSh to face 3rd corner, turn 3rd corner LH & pass partner LSh to face 2nd corner
- 17-24 1s turn 2nd corner RH, pass partner RSh to face 4th corner, turn 4th corner LH to end in 2nd place opposite side facing 2nd corner
- 25-32 1s dance LSh Reels of 3 on opposite sides & cross to 2nd place on own side

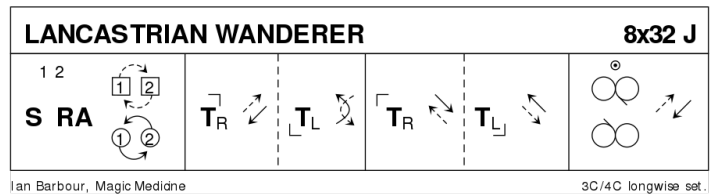

3 RANNOCH MOOR S32 · 5/5L

Roy Goldring: Graded and Social Dances 3 - 16 Dances · Crib: MiniCribS · Diagram: Keith Rose's Diagrams

- 1-4 1s cross down to dance 1/2 Figs of 8 round 2s & 1s dance into middle (2nd place) as 2s step up
- 5-8 1L+2M+3M dance RH across as 1M+2L+3L dance LH across & end in Prom hold facing 3M
- 9-16 1s dance RSh reel of 3 across with 3s ending in 2nd pl & 1s facing 4M
- 17-24 1s dance reel of 3 with 4s into middle with 4s ending in 3rd place & 1s end in middle in 4th place
- 25-28 1L dances RH across with 4M+5M as 1M dances LH across with 4L+5L;
- 29-32 1s cast up round 5s & cross down to 5th place own sides (5s step Up)

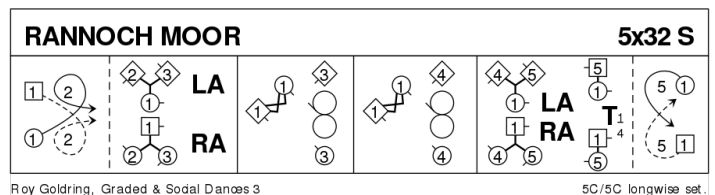

4 THE HIGHLAND RAMBLER R40 · 3/4L

Roy Goldring: Silver Jubilee 25 - Leeds Branch · Crib: MiniCribbs · Diagram: Keith Rose's Diagrams

- 1-8** 1s dance in & cast to 2nd place, dance RH across with 3s
- 9-16** 2s+1s dance LH across, 1L followed by partner cast up round 2L & dance down middle to 1L between 3s & 1M between 2s
- 17-24** 1s+2s+3s dance down the middle & back
- 25-32** 1M followed by partner cast down round 2L to 2nd places on own side & turn RH
- 33-40** 2s+1s+3s circle 6H round & back

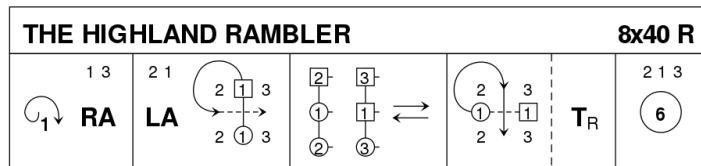

Roy Goldring, 1985, Leeds Silver Jubilee

3C/4C longwise set.

5 THE HIGHLAND RAMBLER R40 · 3/4L

Roy Goldring: Silver Jubilee 25 - Leeds Branch · Crib: MiniCribbs · Diagram: Keith Rose's Diagrams

- 1-8** 1s dance in & cast to 2nd place, dance RH across with 3s
- 9-16** 2s+1s dance LH across, 1L followed by partner cast up round 2L & dance down middle to 1L between 3s & 1M between 2s
- 17-24** 1s+2s+3s dance down the middle & back
- 25-32** 1M followed by partner cast down round 2L to 2nd places on own side & turn RH
- 33-40** 2s+1s+3s circle 6H round & back

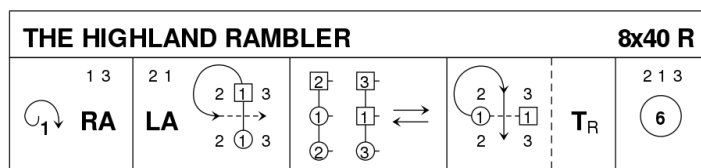

Roy Goldring, 1985, Leeds Silver Jubilee

3C/4C longwise set.

6 THE TATTIE BOGLE J32 · 3/4L

Derek Haynes: Carnforth Collection of SC Dances 1 · Crib: MiniCribbs · Diagram: Keith Rose's Diagrams

- 1-8** 1s set, cross down RH & face partner, set & turn LH to face 1st corners
- 9-16** 1s set to 1st corners, full turn corner RH to dance 1/2 diagonal reel of 4 with 1st corners & pass LSh to face 2nd corners
- 17-24** 1s set to 2nd corners, full turn corner RH to dance a 1/2 diagonal reel of 4 with 2nd corners & into centre
- 25-32** 1M dances RH across with 3s (in 1st place) & 1L dances with 2s, 1s end in 2nd place opposite sides & 2s+1s+3s chase clockwise 1/2 way

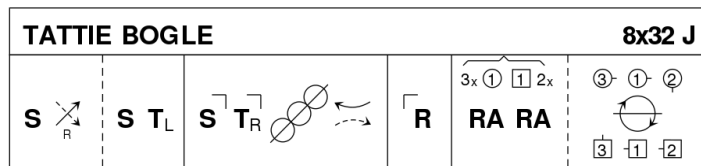

Derek Haynes, 1991, Carnforth Collection

3C/4C longwise set.

7 SANDS OF MORAR S32 · 3/4L

Barry Priddey: RSCDS XLV 6 · Crib: MiniCrib · Diagram: Keith Rose's Diagrams

- 1-8** 1s dance Fig of 8 round 2s giving hands when possible
- 9-16** 1s dance reflection reels of 3 on own sides (1s dance down between 2s to begin)
- 17-24** 1s turn 2H & dance down middle to 3rd pl as 2s+3s continue reel & dance down behind 1s, all set & 1s followed by 2s+3s cast up to orig pls
- 25-32** 1s+2s dance the Tourbillon :
 1s & 2s turn partners 2H 1/2 way, 1M & 2L lead partners on 1 place clockwise to end 1s on Ladies side & 2s on Men's side, 1s set to 2s
 1s & 2s 1/2 turn partners 2H, 1L & 2M lead partners on 1 place to end 2s in 1st pl & 1s in 2nd pl & 2s+1s cross RH to own sides

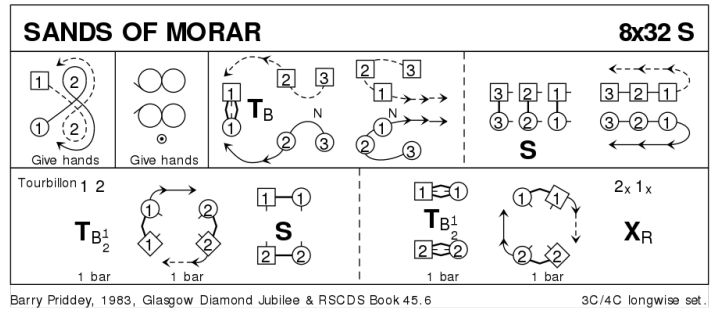

8 FATHER TO SON R32 · 3/4L

Simon Scott: Coast to Coast with Scotch Mist · Crib: MiniCrib · Diagram: Keith Rose's Diagrams

- 1-8** 1s+2s Set & Rotate, 1s end facing up, 2s facing down
- 9-16** 2s+1s+3s dance RSh reels of 3 on sides (1s RSh to 2s to start)
- 17-24** 2s+1s+3s Set+Link for 3 couples twice to end on opp sides, Men facing down, Ladies facing up
- 25-32** 3s+1s+2s chase 1/2 round clockwise to own side (4 bars) & all turn partners RH

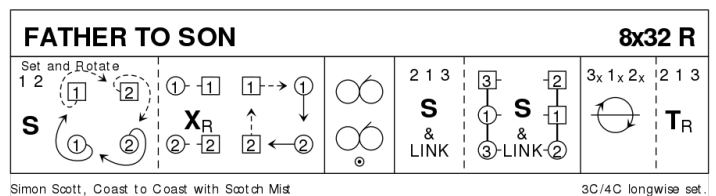

9 THE ELEPHANT'S STAMPEDE J48 · 4S

Lorna Macdonald & Gillian Mackintosh: Aurora 10th Anniversary Book of SCD · Crib: MiniCrib · Diagram: Keith Rose's Diagrams

- 1-8** All circle 8H round & back
- 9-16** 1s+3s advance & with free hand join with 2s & 4s & retire into longwise set across the dance, all dance 1/2 parallel reels of 4 across
- 17-24** All dance 1/2 R&L at each end of set, turn (person on Mans left) RH 1.1/2 times to form Sq.Set
- 25-32** All Ladies petronella turn to next Ladies place to right & set, repeat to meet partner (all have progressed 1 place to right)
- 33-48** All dance full Schiehallion Reel

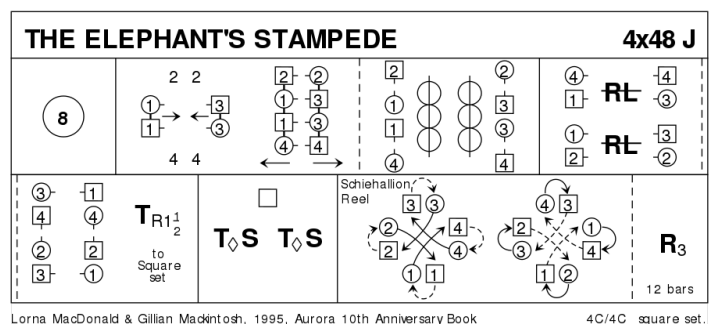

10 THE SILVER GREY S32 · 3/3L

Roy Goldring: Graded and Social Dances 2 - 23 Dances · Crib: MiniCribs · Diagram: Keith Rose's Diagrams

- 1-8** 1s+2s+3s set, cross RH, set & cross back RH
- 9-16** 1s+2s+3s circle 6H round & back, 1s & 3s remaining in the middle facing up/down
- 17-24** 1s+3s dance 3/4 R&L, 1s cast to 2nd place opposite sides as 3s cross over LH
- 25-32** 1s dance 1/2 Fig of 8 round 3s, 1s followed by 3s dance up between 2s & cast, 1s to 3rd place & 3s to 2nd place

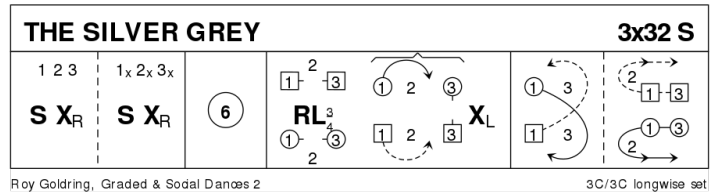

11 STAIRCASE IN STYRIA R40 · 5/5L

Margaret Gray: CD booklet of The Sunday Class Dance Book 2 · Crib: MiniCribs · Diagram: Keith Rose's Diagrams

- 1-8** 1s+2M also 3s+4M dance RH across, 1s+2L also 3s+4L dance LH across
- 9-16** 1s+4M also 3s+5M dance RH across, 1s+4L also 3s+5L dance LH across & 1L also 3L end facing out Ladies side with partners behind them
- 17-24** 1s & 3s dance out Ladies' side & cast up 1 place, cross to Mens side & cast up to original place Ladies looping round by the right
- 25-32** 1s cross & cast 1 place, 1s followed by 3s dance up & cast (1s to 3rd place, 3s to 2nd place)
- 33-40** 1s cross & cast 1 place, 1s followed by 5s dance up & cast (1s to 5th place, 5s to 4th place). 2 3 4 5 1
- NB - No stepping up or down until bar 27

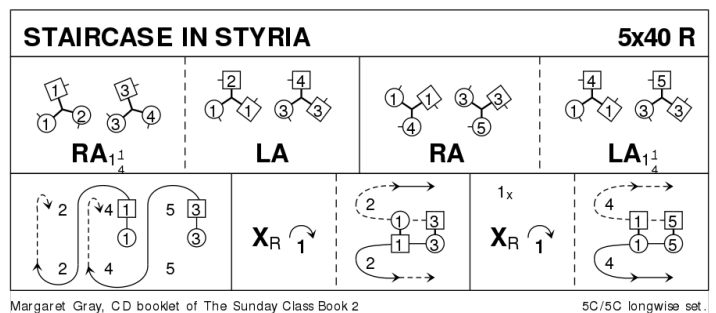

12 MRS STEWART'S JIG J32 · 3/4L

Frans Ligtmans: RSCDS XXXV 1 · Crib: MiniCribs · Diagram: Keith Rose's Diagrams

- 1-8** 1s set, 1L followed by partner casts 2 places, 1L crosses (below 3s) & casts up on Men's side to 2nd place facing down **while** 1M dances round 3L & up the middle to 2nd place Ladies side facing down
- 9-16** 2s+1s+3s dance Grand Chain, end with 2M & 1M facing out
- 17-24** 2s+1s dance Ladies Chain
- 25-32** 2s+1s+3s Adv+Ret for 2 steps & 1s turn 1.1/2 RH to own sides

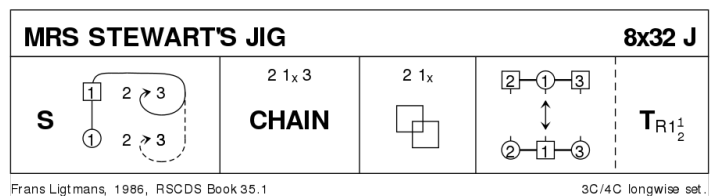

13 MIKE HARDIE'S REEL R40 · 3/4L

Ian Barbour: Magic Medicine · Crib: MiniCrib

- 1-8 1s+2s set, dance RH across & 1s cast to face 1st corners
- 9-16 1s dance 1/2 diagonal reel of 4 with 1st corners, 1/2 reel with 2nd corners ending with 1M between 3s (at top) facing down & 1L between 2s facing up
- 17-24 1s+2s+3s Set+Link for 3 twice
- 25-32 1s dance Figs of 8 across **while** 2s+3s dance R&L (1M passes 3M LSh, 1L passes 2L LSh to start) & 1s end in 2nd place on own side
- 33-40 2s+1s+3s circle 6H round & back

14 IT'S JUST FOR FUN J32 · 3/4L

Roy Fidler: RSCDS XXXIII 6 · Crib: MiniCrib · Diagram: Keith Rose's Diagrams

- 1-8 1s cross RH & cast 1 place, 1M dances 1/2 Fig of 8 round 2s **while** 1L dances round 3s 1s end facing 1st corners
- 9-16 1s dance 1/2 reel of 4 with 1st crnrs, pass LSh & dance RH across (1M with couple in 1st pl & 1L with cpl in 3rd pl) 1s end facing 2nd crnrs
- 17-24 1s dance 1/2 Reel of 4 with 2nd corners, pass partner LSh to dance RH across (1M with 2L+3L on Men's side & 1L with 2M+3M)
- 25-32 1s 1/2 turn LH **while** 2s+3s change places RH on sides, 1M dances up & 1L down, cast on own sides **while** corners set & cross RH & all set

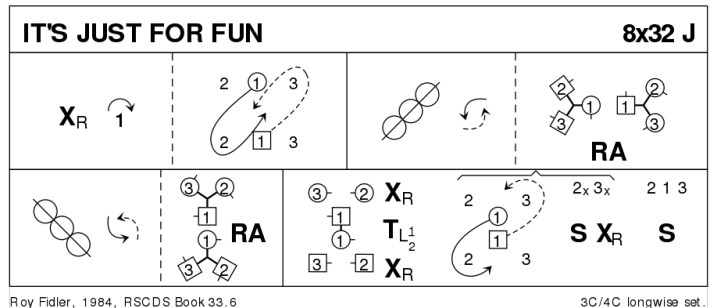

15 MORANBANK S32 · 3/4L

Gary Coull: Jubilee Book 1929-2004 [Banffshire] · Crib: MiniCrib · Diagram: Keith Rose's Diagrams

- 1-8 1s+2s dance RH across 1/2 way, 1s+3s dance LH across once round & 2s+1s dance RH across 1/2 way
- 9-20 1s+2s+3s dance R&L for 3 couples
- 21-24 1s set & cast 1 place
- 25-32 2s+1s dance Diamond Poussette

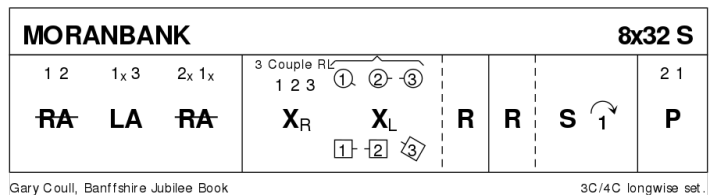

16 MRS STEWART OF FASNACLOICH R32 · 3/4L

RSCDS: *The Leaflet Dances with Music* · Crib: *MiniCrib*s · Diagram: *Keith Rose's Diagrams*

- 1-8** 1s & 2s Petronella turn into centre & set, 3/4 turn partner RH & 1s+2s dance 1/2 RH across (1s end in 2nd place own sides)
- 9-16** 1s cross down RH through 3rd place to dance reel of 3 with 2s+3s on opp sides (2s+3s start passing RSh on Ladies' side & LSh on Men's side). 1s end facing 2nd cnrns
- 17-24** 1s dance 1/2 diag reel of 4 with 2nd corners, turn LH for 1/2 LSh reel with 1st cnrns passing LSh to end BtoB in centre (1M face up 1L down)
- 25-32** 1s circle 3H round to left (Man with 3s & Lady with 2s), 1s drop LH & open up to circle 6H round to left 1/2 way & all set

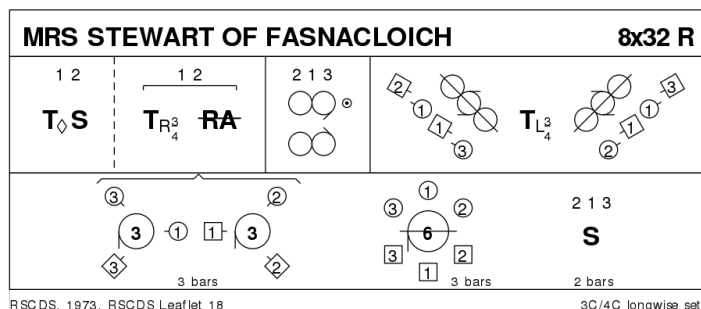

17 THE DIAMOND ANNIVERSARY J32 · 3/4L

Janet Renton: *The Diamond Jubilee Collection (Inverness)* · Crib: *MiniCrib*s

- 1-8** 1s cross RH & cast 1 place, 1s dance down between 3s & cast up to 2nd opposite sides.
- 9-16** 1s turn RH to face 1st corners & turn corners LH, turn 2nd corners RH & partner LH to end facing 1st corners
- 17-24** 1s dance 1/2 reel of 4 with 1st corners & pass LSh to face 2nd corners, 1s dance 1/2 reel of 4 with 2nd corners & end 2nd place opposite sides. 3 1 2
- 25-32** 3s+1s+2s Set+Link for 3 twice. 2 1 3 4

18 THE PAISLEY WEAVERS S32 · 3/3L

Derek Haynes: *A Third Book of Graded Scottish Country Dances* · Crib: *MiniCrib*s · Diagram: *Keith Rose's Diagrams*

2s start on opposite sides

- 1-8** 1s cross down RH & cast down behind 3s, cross up RH & cast up round 2s
- 9-16** 1s+2s+3s dance Grand Chain, 1M & 2M face out
- 17-24** 1s+2s dance Ladies' Chain
- 25-32** 1s+2s dance 1/2 R&L (Men polite turns), 1s+3s dance 1/2 R&L

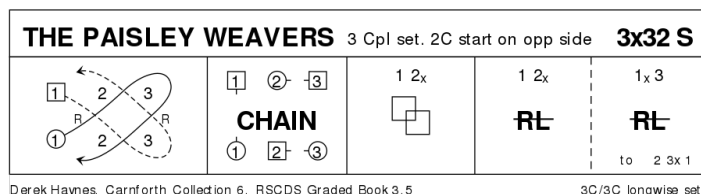

19 MILTON'S WELCOME R32 · 3/4L

John Bayly: RSCDS XXXIII 8 · Crib: MiniCribbs · Diagram: Keith Rose's Diagrams

- 1-8** 1s+2s+3s set, cross RH, 1s+2s+3s set & 1s+3s 3/4 turn RH (to form line up & down centre) as 2s cross RH to original places
- 9-16** 1s+3s dance reel of 4 in centre of dance end with 1L+3M taking LH as partners end on sides
- 17-24** 1L+3M 3/4 turn LH to face own sides, dance out & cast behind 2s to original places, 1s+2s+3s turn LH
- 25-32** 1s+2s dance Poussette. 2 1 3

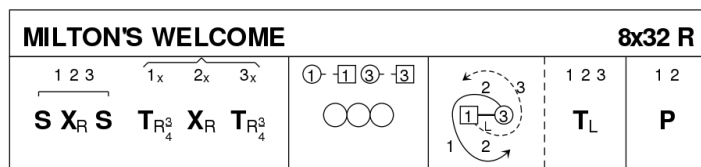

John Bayly, 1974, RSCDS Book 33.8

3C/4C longwise set.

20 THE FLIGHT OF THE FALCON J32 · 3/4L

Barry Priddey: Anniversary Tensome · Crib: MiniCribbs · Diagram: Keith Rose's Diagrams

- 1-8** 1s set, cast 1 place & turn LH to 1M facing his 1st corner with his partner behind him
- 9-16** 1M followed by partner dance a full RSh diagonal Alternating Tandem reel of 3 with 1st corners & end facing Ladies 2nd corner
- 17-24** 1M followed by partner dance a RSh Alternating Tandem reel of 3 with 2nd corners & 1s end facing own 1st corners
- 25-32** 1s turn 1st corners RH, pass RSh, turn 2nd corner RH & pass RSh to 2nd place own sides (corners turn for 4 bars)

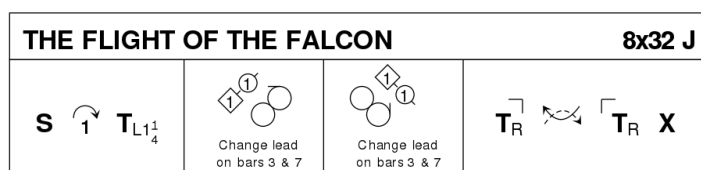

Barry Priddey, Anniversary Tensome

3C/4C longwise set.

21 THE SWAN AND THE TAY S32 · 3/3L

Audrey Saunders: Scottish Country Dances for Perth 800 · Crib: MiniCribbs · Diagram: Keith Rose's Diagrams

- 1-8** 1s dance Figs 8 own sides dancing in & down to start (giving hands where possible)
- 9-16** 1s cross down to dance reels of 3 on opp sides (joining hands where possible) & 1s end facing 1st corners, 2s end in 1st place
- 17-20** 1s dance Corners Pass+Turn with 1st cnrs, pass RSh on bar 20 to face 2nd cnrs
- 21-24** 1s dance Corners Pass+Turn with 2nd cnrs. Pass RSh on bar 24 to end 2nd place own sides
- 25-32** All set, all cross RH, all chase clockwise 1/2 way round to own sides 3 1 2

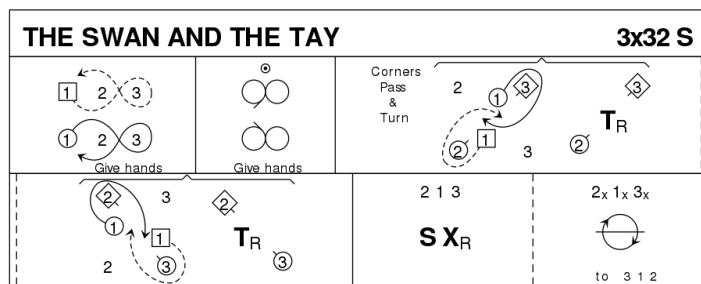

Audrey Saunders, Scottish Country Dances for Perth 800

3C/3C longwise set.

22 THE GUESTS AT MAIRI'S WEDDING

R40 · 5/5L

George Gaze: *The Dookie Bookie* · Crib: *MiniCribs* · Diagram: *Keith Rose's Diagrams*

- 1-8** 1s also 3s turn RH & cast 1 place, turn LH to face 1st corners
- 9-16** 1s also 3s dance 1/2 Diagonal reel of 4 with 1st corners, 1/2 Diagonal reel with 2nd corners
- 17-24** 1s also 3s dance 1/2 Diagonal reel with 3rd corner (pstns), 1/2 Diagonal reel with 4th corner (pstns)
- 25-32** 1s also 3s dance Diag R&L (M down).
2 1 4 3 5
- 33-40** 1s dance down to 5th place **while** 3s dance in & cast up to 2nd place as 5s step up, all turn RH.
2 3 4 5 1

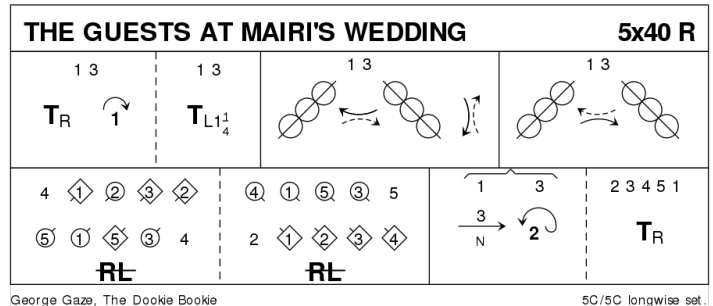

23 THE LAST OF THE LAIRDS

J32 · 3/4L

Hugh A Thurston: *RSCDS XXII 5* · Crib: *MiniCribs* · Diagram: *Keith Rose's Diagrams*

- 1-8** 1s cross down (each couple cross down as they reach top place) to dance reflection reels of 3 on sides
- 9-16** 1s cross down (each couple cross down as they reach top place) to dance reflection reels of 3 on sides
- 17-24** 1s set & cross RH then cast 1 place, cross down between 3s & cast up to 2nd place on own sides
- 25-32** 1s lead up between 2s & cast down 1 place, 2s+1s+3s turn RH

