

Laurencekirk, Dickson Hall. Sat 16 Nov 7:30

1 CRAMOND BRIDGE R32 · 3/4L

Valerie Farr: *The London Jubilee Book* (1979) · Crib: *MiniCribs* · Diagram: *Keith Rose's Diagrams*

- 1-8 1s cross RH & cast 1 place, cross LH & cast (Lady up, Man down), to meet in middle in prom hold facing 2nd Man
- 9-16 1s dance 1/2 diagonal reel with 1st corners & 1/2 reel with 2nd corners, end in middle facing Ladies' side
- 17-24 1s lead out, cross & cast (Lady up, Man down) to meet in middle, 1s turn RH as 2s+3s dance 1/2 R&L round them
- 25-32 1s lead up & cast to 2nd place & 2s+1s+3s turn partners RH

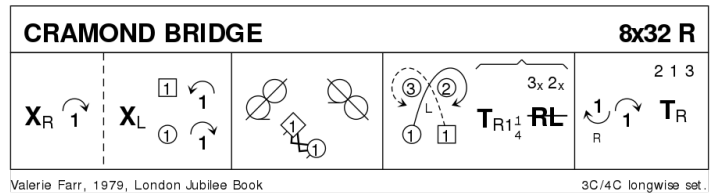

2 LIAM'S JIG J32 · unknown/4L See bottom of this page

Neil M Grant

3 BROADWAY S32 · 3/3L

Chris Ronald: *The Sunday Class Dance Book 2* · Crib: *MiniCribs* · Diagram: *Keith Rose's Diagrams*

- 1-8 1s dance down (2 bars) & turn 2H (2 bars), 1s dance up & cast to 2nd place
- 9-16 2s+1s+3s Set+Link for 3, 1s dance 1/2 Diag R&L starting Diagonally left
- 17-24 All Set+Link for 3, 1s dance 1/2 Diag R&L starting Diagonally left. (3)(1)(2)
- 25-32 All set & 1/2 turn RH, face partner and pull back RSh, dance out to places & set. 3 1 2

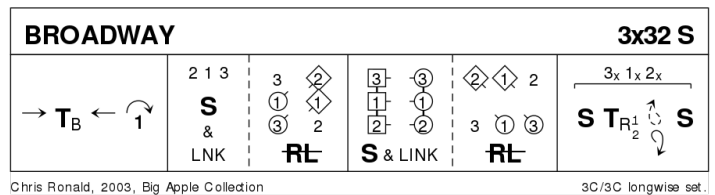

LIAM'S JIG (J8x32) 3C (4C set) Neil M Grant 2002

1- 8 1s and 2s nearer hands joined Set. RH Wheel once round, 1s Cast off 1 as 2s Dance to top nearer hands joined.

9- 16 1s and 3s Double figure of 8. 1s Cross down as 3s Dance up side to start.

End 1s 2nd place facing up just outside the line, 3s own place facing out.

17-24 2, 1, 3W LH Wheel as 2, 1, 3M RH Wheel. Bar 20 1s Cross down diagonally, followed by others in their wheel, Dance up opposite side, 1s Cast off 1, 3s top place facing out, 2s, 3rd place facing out. (3)(1)(2)4

25-28 3s, 1s, 2s 1/2 Reel 3 across RSh: 1W up, 1M down. End on sides facing way of travel.

29-32 3s, 1s, 2s 1/2 Reel of 3 on own side LSh. 213

(Dance Crib compiled by <http://www.rscdshamiltonandclydesdale.org.uk>)

4 ANNE AND FIVE PARTNERS J48 - 5/5L

John Brenchley: *The Kangaroo Paw* · Crib: *MiniCribs* · Diagram: *Keith Rose's Diagrams*

- 1-4** 1L+3M also 3L+5M set to each other & cast 1 place (Ladies down, Men up)
- 5-8** 1L & 3L dance LSh round Lady below & in to face 2nd corner (pstn) **while** 3M & 5M dance LSh round Man above & in to face 2nd corner
- 9-16** 1L+3M also 3L+5M turn 2nd corners RH, each other LH, 1st corners RH & each other LH to face 4th corners (pstn)
- 17-24** 1L+3M also 3L+5M dance diagonal reels of with 4th corners & end facing 3rd corners (pstn)
- 25-32** 1L+3M also 3L+5M dance diagonal reels of with 3rd corners & end facing 2nd corners (pstn)
- 33-40** 1L+3M also 3L+5M set to 2nd corners & turn right about to face each other (up/down) & set, turn RH 1.1/4 times to face 1st corners (pstn)
- 41-48** 1L+3M also 3L+5M set to 1st corners & turn right about to face each other & set (across), cross RH & cast 1 place (Ladies down, Men up)
- to end: - Ladies' side: 2L 4L 1L 5L 3L Men's side: 3M 1M 5M 2M 4M

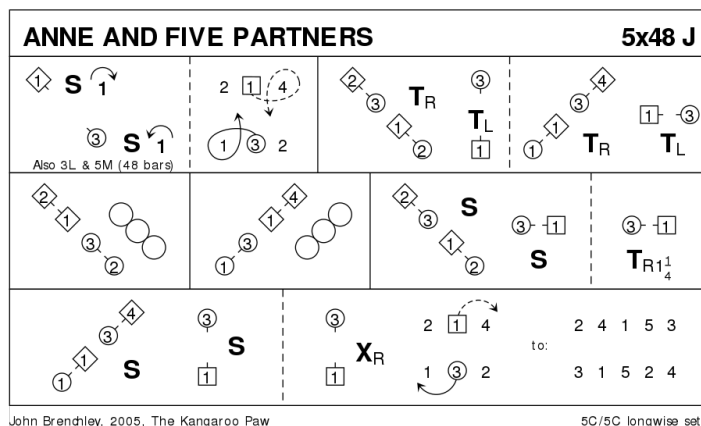

5 THE WHISTLING WIND R32 - 3/4L

Elizabeth Goossen: *RSCDS XXXVI 5* · Crib: *MiniCribs* · Diagram: *Keith Rose's Diagrams*

- 1-8** 1s set, dance in & cast to 2nd place, set to each other **while** advancing to 1st corners
- 9-16** 1s dance 1/2 reel of 4 with 1st corners, pass by RSh to dance 1/2 reel with 2nd corners. 1s end in centre BtoB, 1M facing up, 1L facing down
- 17-24** 3s+1s+2s dance Double Triangles facing up & down, 1s ending in 2nd place on own sides
- 25-32** 1s dance Diag R&L

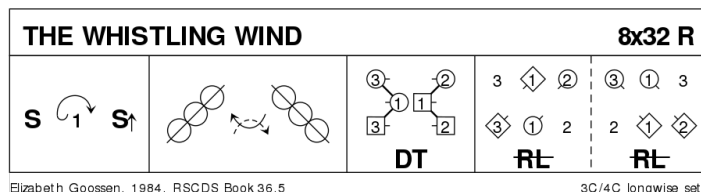

6 LINNEA'S STRATHSPEY S32 · 3/4L

Tim Wilson: RSCDS XLVII 2 · Crib: MiniCribs · Diagram: Keith Rose's Diagrams

- 1-8** 1s set & cast 1 place, 1s cross passing LSh & cast RSh round 1st corners into face them
- 9-16** 1s dance 'Hello-Goodbye' setting & end passing RSh to face out in 2nd place own sides
- 17-24** Promenade (Chaperoned) Chain progression:
17-18 2s & 3s 3/4 turn partner RH into middle **while** 1s dance clockwise 1/4 round the set picking up 2L/3M ...
19-22 who promenade 1/2 way clockwise **while** middle people (2M + 3L) turn LH 1.1/2.
23-24 2s & 3s turn partner RH 3/4 to own sides **while** 1s dance clockwise 1/4 round to end in 2nd place, all 3 couples in middle facing up 3 1 2
- 25-32** 3s+1s+2s dance Allemande

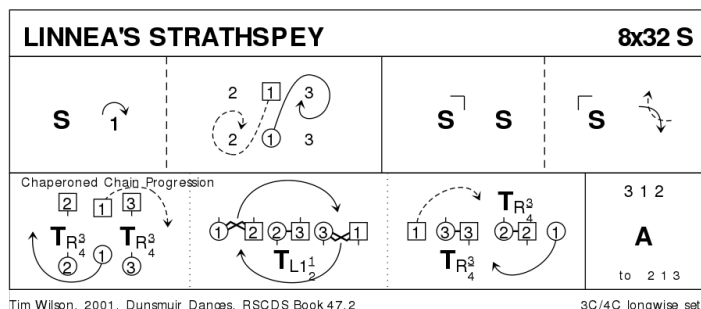

7 THE WEATHERCOCK J32 · 4/4L

Veronica Hughes: A Second Book of Graded Scottish Country Dances · Crib: MiniCribs · Diagram: Keith Rose's Diagrams

- 1-8** All dance RSh reels of 4 on own sides
- 9-16** 1s & 3s set advancing into centre (give RH to partner) & Bal-in-Line, 1s+2s & 3s+4s dance RH across once round
- 17-24** Centre couple (1L+3M) 3/4 turn LH in centre **while** 1M & 3L dance round crnr to meet ptr in line across & set, repeat & set in line up/down dance
- 25-32** 3s+2s & 1s+4s dance RH across once round, turn facing corner RH (2L+3L, 3M+2M, 1L+4L & 1M+4M) onto own sides (Ladies turn 1.1/2 **while** Men turn once round). 2 3 4 1

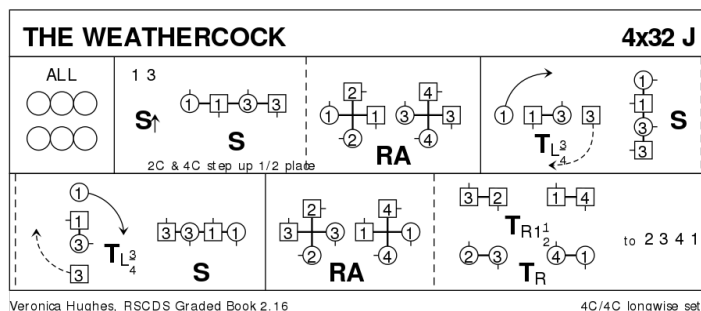

8 THE TRI-MARINER R32 · 3/4L

Ann Dix: RSCDS XLVIII 8 · Crib: MiniCribs · Diagram: Keith Rose's Diagrams

- 1-8** 1s set, cast 2 places & lead up to top **while** 2s (bar 3) set, cast 1 place & lead up to 2nd place **while** 3s (bar 5) set, cast into middle
- 9-16** 1s+2s+3s Promenade & end with 1s casting to 2nd place
- 17-24** 1s cross down, cast up behind 3s, cross up & cast to 2nd place
- 25-32** All petronella turn into middle, set & turn partner RH 1.1/4 times

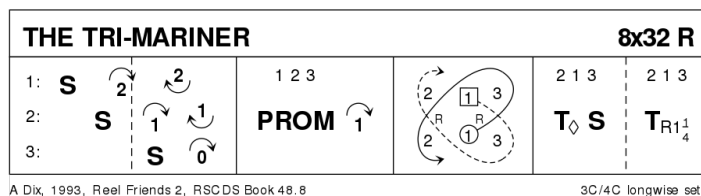

9 BUTTERSCOTCH AND HONEY S32 · 4/4L

Jean Attwood: Alexander Leaflets · Crib: MiniCribbs · Diagram: Keith Rose's Diagrams

- 1-8** 1s set & 1/2 turn RH into prom hold, 1s dance 1/2 RSh reel of 3 with 2s (2s end on opposite sides)
- 9-16** 1s dance 1/2 LSh Reel of 3 with 3s & 1/2 RSh reel of 3 with 4s
- 17-24** 1s followed by 4s+3s+2s cast up on opposite sides to top, cross over to own sides each Lady passing in front of partner & down own side
- 25-32** All set to partners & turn 2H into 4H round (2s with 3s & 4s with 1s)

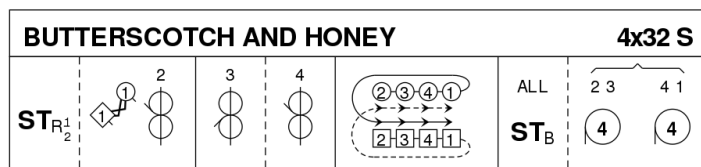

10 THE COURTSHIP R40 · 3/4L

Amanda Peart: The Sunday Class Dance Book 2 · Crib: MiniCribbs · Diagram: Keith Rose's Diagrams

- 1-8** 1s+2s+3s dance »Inveran Reels«
- 9-16** 1s cross RH, cast (2s step up) to face 2nd corners. 1s+2nd corners dance »Pass & Gypsy Turn«
- 13-16** 1s dance RSh around corner positions back into centre **while** corners dance round each with RSh »Gypsy Turn«
- 17-24** 1s dance round each with RSh »Gypsy Turn« to face 1st corners. 1s+1st corners dance »Pass & Gypsy Turn«. 1s turn RH into prom hold facing 1M place
- 25-32** 1s dance 1/2 reel of 3 on Men's side (1s+2M pass RSh). 1s dance 1/2 reel of 3 on Ladies' side (1s+3L pass RSh). 1s end in centre facing up, 2s+3s dance in ready for...
- 33-40** 3s+1s+2s dance Allemande

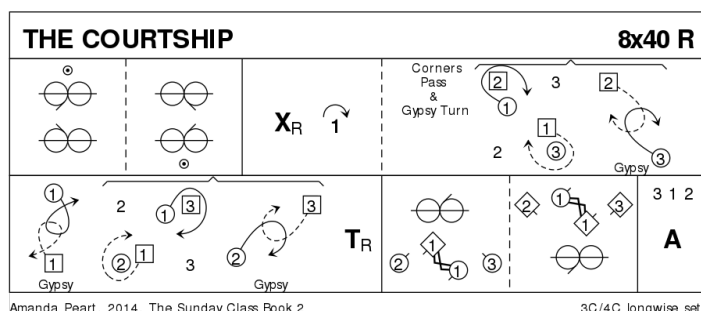

11 WELCOME TO DUFFTOWN J32 · 3/4L

Jessie Stuart · Crib: MiniCribbs · Diagram: Keith Rose's Diagrams

- 1-8** 1s 3/4 turn RH moving down (2s step up) & dance 6 bars Crown Triangles ending with Man between 2s & Lady between 3s all facing down
- 9-16** 1M+2s also 1L+3s dance down the middle & back 1M+2s turning to face 1L+3s
- 17-24** 1s change places RH, cast to right to 2nd place & turn RH **while** 2s+3s set facing on sides, change places RH, set to partner & cross RH
- 25-32** 1s dance diag R&L

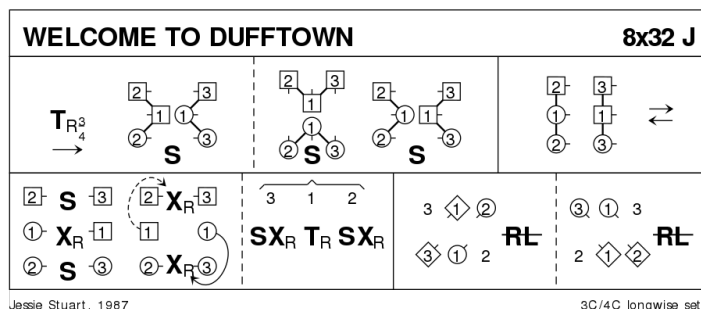

12 TRIPLE HAPPINESS S32 · 3/3L

Yoshiki Oyama: RSCDS LII 10 · Crib: MiniCribbs · Diagram: Keith Rose's Diagrams

- 1-8** 1s Adv+Ret (1 step each) taking RH briefly, 1s 1/2 turn LH, cross down between 2s & cast up to place
- 9-16** 1s+2s dance the Knot. 1s end facing 1st corners
- 17-24** Corners Pass & Turn with 1st corners, pass RSh, Repeat with 2nd corner & 1s pass RSh into 2nd place own sides (corners turn 2H in centre)
- 25-32** All chase clockwise 1/2 round to opp sides, all 1/2 turn 2H, pull back RSh & dance out to own sides 3 1 2

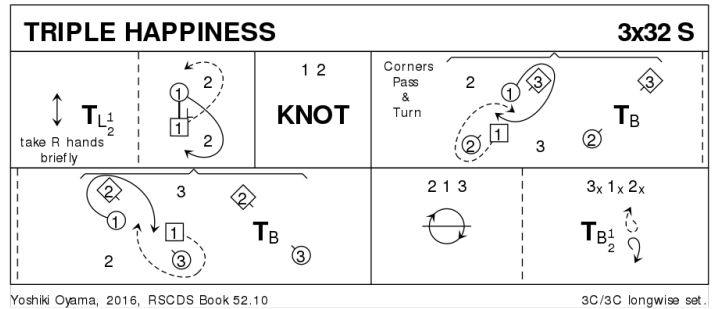

13 REEL OF THE PUFFINS R32 · 4/4L

John Bowie Dickson: Dunedin Dances Book 5 · Crib: MiniCribbs · Diagram: Keith Rose's Diagrams

3s & 4s start on opp sides

- 1-8** 1s & 4s cross RH & cast in 1 place to join hands to form a circle, set twice turning right about to face nearest corner
- 9-16** 2s & 3s dance full diagonal RSh reels of 4 giving LH in centre **while** 1s & 4s dance 1/2 diagonal RSh reel & pass LSh in centre to face next corner anticlockwise; dance 1/2 RSh reel with that corner & pass LSh in centre to face next corner anticlockwise
- 17-24** 4s & 1s turn corners RH & dance LH across 1/2 way, turn diagonally opposite corners RH & 1s+4s change places LH on the sides
- 25-32** All dance RSh reels of 4 on sides. 2 4 (1)(3)

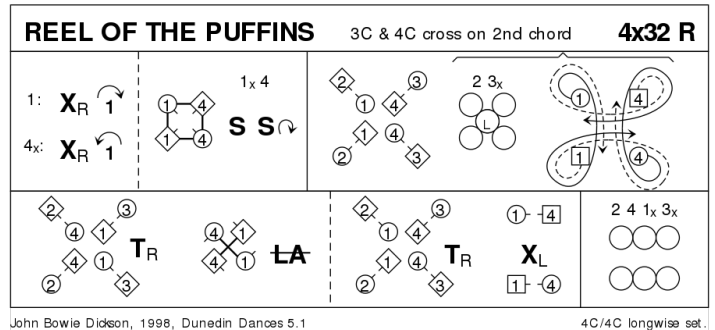

14 THE AVIATOR J32 · 3/4L

Carola Fischer: RSCDS LII 9 · Crib: MiniCribbs · Diagram: Keith Rose's Diagrams

- 1-8** 1s lead down, on bar 4 1M crosses partner in front & 1L followed by 1M cast up behind 4M & 3M & across into 2nd place facing 3L (2s step up 3-4)
- 9-16** 1s (1L leading) dance 1/2 alternating tandem reel with 1st corners; 1M continues reel with corners passing 3L LSh **while** 1L+3M turn LH to face 2L
- 17-24** 1s (1M leading) dance 1/2 alternating tandem reel with 2nd corners; 1L continues reel with corners passing 2L LSh **while** 1M+3L turn LH. 1s end in 2nd place opp sides, 1L facing out
- 25-32** 1s dance up, round 2s by RSh (1L behind 2M, 1M in front 2L) & 1M followed by 1L cast 1 place, across set to end in 2nd place own side (6 bars). All 3 couples set

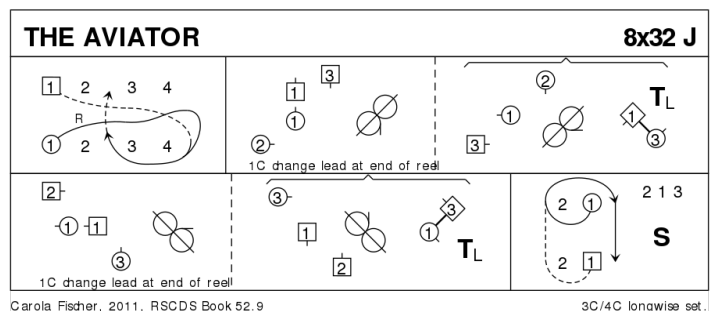

15 THE MERCHANT CITY S32 · 3/3L

Anne Thorn: *Magic of Music, Book 2* · Crib: *MiniCribs* · Diagram: *Keith Rose's Diagrams*

- 1-8** 1s & 2s dance the Espagnole:
1- 2 1s+2s cross (Ladies lead across RH passing between Men) with Ladies changing places RH
3- 4 1s+2s cross back (Men lead across RH between Ladies) with Men changing places RH
5- 8 2s turn RH as 1s turn LH
- 9-16** 1M with 3s, 1L with 2 dance RH
 Across, 1s pass by right; 1M with 2s, 1L with 3s dance LH Across (2 1 3)
- 17-24** 1s & 3s dance the Rosette:
17-20 1s & 3s set, turn partner RH 1/2 way, face partner, drop hands, pull back RSH & cast to opp sides (partner's place)
21-24 1s & 3s dance clockwise 1/2 way round to new positions (2 3 1)
- 25-32** 2s, 3s & 1s dance 6 hands round and back

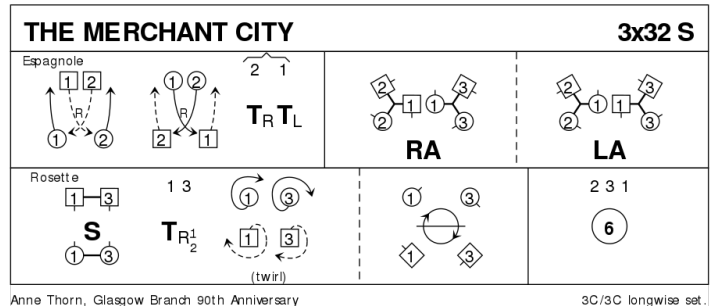

16 THE RUBY RANT R32 · 3/4L

Francis Walduck: *RSCDS XLIX 6* · Crib: *MiniCribs* · Diagram: *Keith Rose's Diagrams*

- 1-8** 1s+2s set, pull back RSh, dance 2 places clockwise, cross RH to own sides. 1s face out
- 9-12** 2s+1s+3s dance 1/2 reels of 3 on sides (1M+2M also 1L+3L pass RSh) Bars 11-12: 1L (from 3L place) & 1M (from 1M place) dance across to 2nd place opp sides & face out
- 13-16** 3M+1L also 1M+2L turn RH
- 17-20** 3s+1s+2s dance 1/2 reels of 3 on sides (1L+2M also 1M+3L pass LSh) Bars 19-20: 1L (from 3M place) & 1M (from 1L place) dance across to 2nd place own sides & face out
- 21-24** 2L+1L also 1M+3M turn LH, 1s passing LSh to B-to-B facing opp sides (2L+3M dance 4 bars)
- 25-32** 2s+1s+3s set as Double Triangles. All set again as 1s turn Right about to face & turn RH 1.1/2 to 2nd place own sides

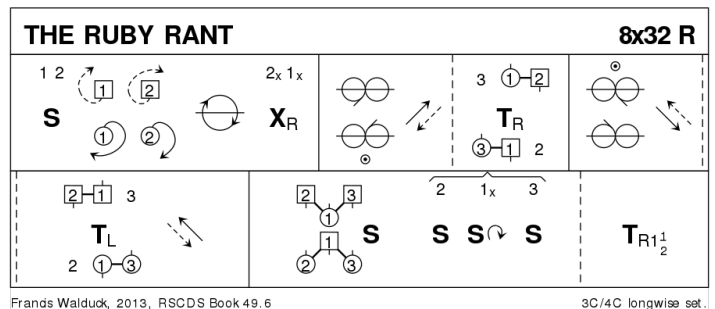

17 THE CRANBERRY TART J32 · 3/4L

Terry Glasspool: Dances from the Seven Year Itch · Crib: MiniCrib · Diagram: Keith Rose's Diagrams

- 1-8** 1M sets & casts 1 place, sets & petronella turns between 3s facing up **while** 1L stands for 2 bars then sets, casts 1 place & sets
- 9-16** 1M sets in line with 3s & all 3 Adv+Ret then 1M advances to partner **while** 1L petronella turns between 2s & sets in line with 2s then all 3 Adv+Ret
- 17-24** 1L followed by partner dances reel of 3 across with 2s (RSh to 2L) to end in 2nd place own sides
- 25-32** 1s dance RSh reels of 3 on sides giving RSh to 3s

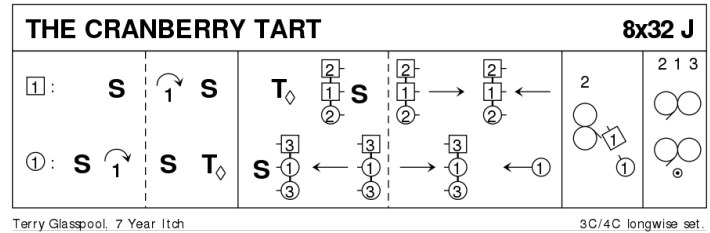

18 BRIDGE OVER THE ATLANTIC S32 · 3/3L

Haynes, Derek & Gradon, John: Carnforth Collection of SC Dances 3 · Crib: MiniCrib · Diagram: Keith Rose's Diagrams

- 1-8** 1s+2s+3s dance reflection reels of 3 on sides (1s in & down to start), 1s+2s continue reel to change places & 1s turn to face up on outside
- 9-16** All dance 3H across on sides (Ladies LH & Men RH), on bar 10 1s cross to join opposite wheel (Lady in front of Man), on bar 13 1s cross back to own side to continue wheels & rotate until 1s are at the top
- 17-24** 1s followed by 3s+2s dance down the middle & back with 3s & 2s dividing to dance up behind 1s in order 1 3 2
- 25-32** All dance Allemande to end 2 3 1

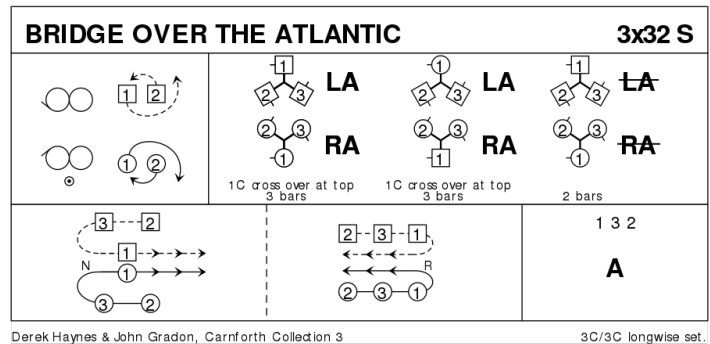

19 CATCH THE WIND R32 · 3/4L

Romaine Butterfield: RSCDS XLV 5 · Crib: MiniCrib · Diagram: Keith Rose's Diagrams

- 1-8** 1s set, cast 1 place & dance 1/2 Fig of 8 round 2s
- 9-16** 1s set twice with 1L pulling back RSh on bars 11-12 to face out, 1L followed by partner casts up & dances down the middle 1L to face 3M **while** 1M faces 2M
- 17-24** 1s RSh reels of 3 across (1M with 2s & 1L with 3s)
- 25-32** 1L followed by partner dances down cast up round 3M & crosses to end in 2nd place on own sides, 1s turn RH (4 bars)

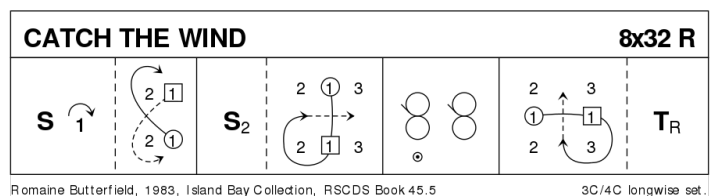

20 GOOD HEARTED GLASGOW

J32 · 3/4L

Peter Knapman: Collins Pocket Reference: Scottish Country Dancing · Crib: MiniCribbs · Diagram: Keith Rose's Diagrams

- 1-8** 1s turn RH & cast to 2nd place, turn partner LH 1.1/4 times
- 9-16** 1s dance RH across (Lady with 2s at top & Man with 3s); 1s pass RSh & dance LH across with other couple
- 17-24** 1s lead down the middle & back to 2nd place own side
- 25-32** 2s+1s+3s circle 6H round & back

GOOD HEARTED GLASGOW					8x32 J
$T_R \curvearrowright 1$	$T_{L1\frac{1}{4}}$	$\overbrace{2 \boxed{1} \quad \boxed{1} 3}$ RA RA	$\overbrace{2 \textcircled{1} \quad \boxed{1} 3}$ LA LA	\longleftrightarrow	$2 \ 1 \ 3$ 6
Peter Knapman, 1988, Collins Pocket Reference					3C/4C longwise set.