

Laurencekirk, Dickson Hall. Sat 14 Nov 7:30

1 INVERNEILL HOUSE R32 · 3/4L

John Drewry: RSCDS XXXV 2 · Crib: MiniCribs · Diagram: Keith Rose's Diagrams

- 1-8 1s+2s dance 1/2 double Fig of 8 (1s cross down), 1s dance down between 3s as 2s dance out & up then 1s cast up to 2nd place opp sides
- 9-16 1s+3s dance 1/2 double Fig of 8 (1s cross down), 1s dance up between 2s & cast to 2nd place own sides
- 17-24 1s Petronella to opposite sides
- 25-32 2s & 3s Petronella to own sides **while** 1s cast RSh round 1st corner & cross between 2s/3s, 1s cast to 2nd place own sides & all set

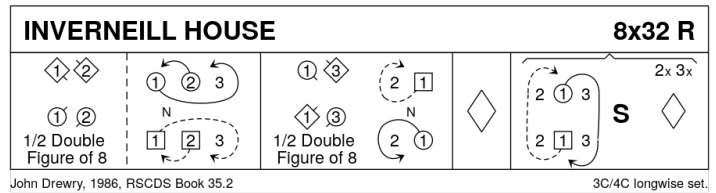

2 THE CRAWFORDS OF KERRERA J32 · 3/4L

Ann Dix: Reel Friends Book 3 · Crib: MiniCribs

- 1-8 1s set, cross RH, cast (2s step up); 1s turn LH to face 1st corners
- 9-16 1s dance 1/2 reel of 4 with 1st corners, pass LSh & dance 1/2 reel of 4 with 2nd corners. End in 2nd place opp sides (3) (1) (2)
- 17-24 3s+1s+2s Set+Link for 3 & circle 6H 1/2 round to Left. End 1M between 3s at top facing down, 1L between 2s facing up
- 25-32 All Set+Link for 3 & circle 6H 1/2 round to Left. End 2 1 3

3 BROADWAY S32 · 3/3L

Chris Ronald: The Big Apple Collection · Crib: MiniCribs · Diagram: Keith Rose's Diagrams

- 1-8 1s dance down (2 bars) & turn 2H (2 bars), 1s dance up & cast to 2nd place
- 9-16 2s+1s+3s Set+Link for 3, 1s dance 1/2 Diag R&L starting Diagonally left
- 17-24 All Set+Link for 3, 1s dance 1/2 Diag R&L starting Diagonally left. (3)(1)(2)
- 25-32 All set & 1/2 turn RH, face partner and pull back RSh, dance out to places & set. 3 1 2

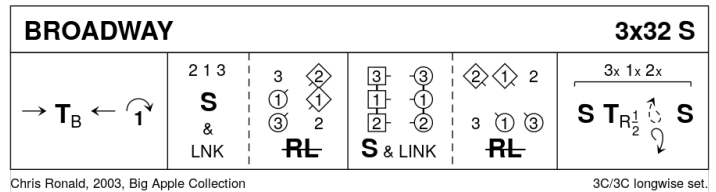

4 TRIP TO TIMBER RIDGE R32 · 3/4L

Linda Henderson: RSCDS LII 12 · Crib: MiniCribbs · Diagram: Keith Rose's Diagrams

- 1-8** 1s turn RH, cast (2s step up) then 1L+2s & 1M+3s dance RH across. 1s end facing 1st corners
- 9-16** 1s dance Corner Pass+Turn with 1st corners, pass RSh & repeat with 2nd corners. 1s pull back RSh to end BtoB in centre facing opp sides
- 17-24** 2s+1s+3s dance Double Triangles. Bars 23-24 1s petronella turn to 2nd place own sides
- 25-32** 2s+1s+3s circle 6H round and back

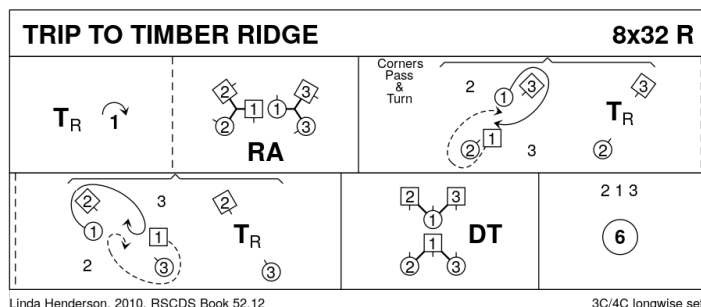

5 A TRIP TO THE DRAKENSBERG J40 · 3/4L

Barbara J. Rendle-Braine: RSCDS XXXVIII 8 · Crib: MiniCribbs · Diagram: Keith Rose's Diagrams

- 1-8** 1s set, cast 2 places & dance up to top (end with 2s stepping in below 1s)
- 9-16** 1s+2s dance Poussette (end with 1s facing 1st corners)
- 17-24** 1s dance 1/2 diagonal reel of 4 with 1st corners, pass LSh & dance 1/2 reel with 2nd corners (1s end 2nd place opposite side)
- 25-32** 3M+1M+2M petronella turn into centre & set **while** 3L+1L+2L set & petronella turn into centre, all turn partners RH (end in Allemande hold)
- 33-40** 3s+1s+2s dance Allemande

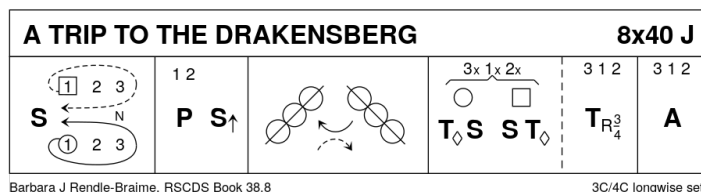

6 SLYTHERIN HOUSE S32 · 3/4L

Chris Ronald: RSCDS LII 3 · Crib: MiniCribbs · Diagram: Keith Rose's Diagrams

- 1-8** 1s+2s Set+Link; circle 4H round to Left 2 1 3
- 9-16** 1s pull back RSh & cast round 3rd corner (Man up/Lady down), pass LSh in centre & dance LSh round 1st corner (6 bars) 1s turn 3/4 LH to end in centre 1M below 1L, facing opp sides
- 17-20** 1L+2s & 1M+3s dance RH across
- 21-24** "Snake Pass": 1L followed by 2L & 2M, 1M followed by 3M & 3L, pass LSh in the middle, dance out to the side, down to 3rd/up to 1st place, cross to own side and cast up/down to 2nd place in middle, RSh to RSh facing opp sides
- 25-28** 1M+3s (at top) & 1L+2s (at bottom) dance LH across
- 29-32** Repeat "Snake Pass" with dancers passing RSh in middle & all finish on sides 2 1 3

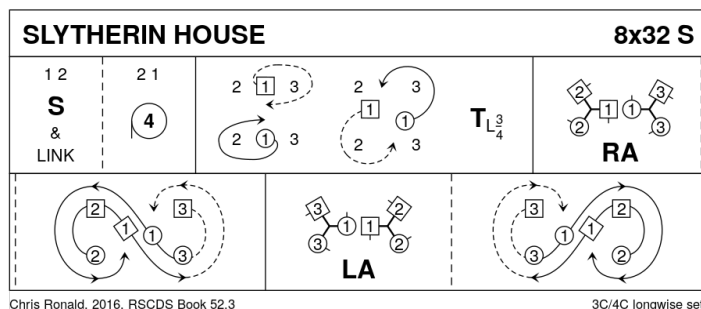

7 THE SALTIRE SOCIETY REEL R32 · 3/4L

Roy Goldring: *The Leaflet Dances with Music* · Crib: *MiniCrib*s · Diagram: *Keith Rose's Diagrams*

- 1-8** 1s cross down & dance out between 2s+3s turning 3s by near hand to meet ptrnr, dance up & turn 2s by nearest hand to 2nd place opp sides
- 9-16** 1s cross down to 3rd pl & dance reel of 3 own side (2s dance out/down as 3s dance out/up b'tw'n 2s), 1s end (hold LH) facing 1st cnrns
- 17-24** 1s set to 1st cnrns, turn inwards & set to 3rd corner as 3rd cnrns set adv to dance RH across with 1s, 1s end turning to face 2nd cnrns
- 25-32** 1s repeat bars 17-24 with 2nd/4th corners but dancing LH across

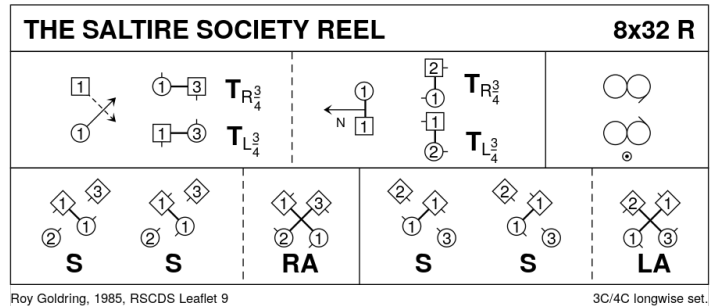

8 PRINCE CHARLIE'S QUICKSTEP J48 · 4/4L

John Drewry: *Summer Collection, Set 8* · Crib: *MiniCrib*s · Diagram: *Keith Rose's Diagrams*

3s and 4s start on opposite sides

- 1-8** 1s and 4s set, ½ turn partners LH, 1L followed by partner dances down, out between 2M+3L, 1L casts to 4th place as 1M casts back to place **while** 4L followed by partner dances up, out between 2L+3M, 4L casts up to 1st place as 4M casts back to place
- 9-16** 1M+4L double Fig of 8 with 2s at top (1M+4L cross down, 2s dance up) **while** 1L+4M double Fig of 8 with 3s at bottom (1L+4M cross up, 3s dance down)
- 17-24** 1M+4L also 1L+4M set, change places RH, all set, 4L and 1L dance across to other side between 2s+3s (who cast up/down to 1st/4th place) **while** 1M and 4M dance across to end BtoB facing partners 1s on Men's side, 4s on Ladies side
- 25-32** 1s+4s RSh reel of 4 across and end with Men giving RH in passing and LH to partner so that 1s face up and 4s down (in line across Men in centre)
- 33-40** 1s+4s in line rotate clockwise ½ way, 1L dances down between 3s and casts up to 3rd place as 4L dances up and casts to 2nd place **while** Men continue to rotate to new places (opposite partners)
- 41-48** All circle 8H round and back

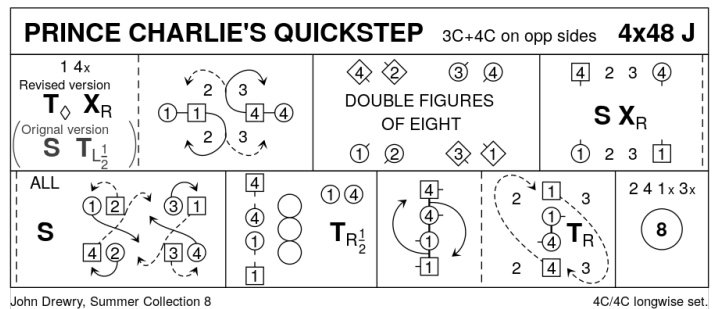

9 THE BON VIVEUR M64 · 4S

Ian Brockbank: *RSCDS LII 11* · Crib: *MiniCrib*s · Diagram: *Keith Rose's Diagrams*

- 1-8** All circle 8H round & back
- 9-16** 1s+3s dance Men's Chain finish with Ladies facing out
- 17-28** All dance Schiehallion reels (12 bars) to finish 1 place clockwise from starting place 4 1 2 3
- 29-32** All birl (or turn) partners RH End 4 1 2 3

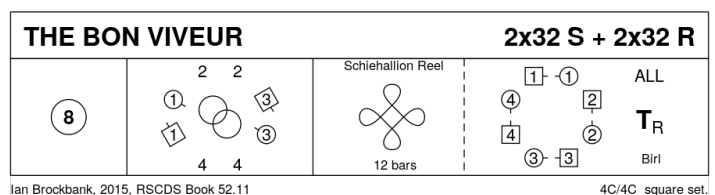

Note: Dance twice as Strathspey, twice as Reel

10 SHIFTIN' BOBBINS R32 · 3/4L

Roy Clowes: *Thirty Popular Dances, Volume Two* · Crib: *MiniCribs* · Diagram: *Keith Rose's Diagrams*

- 1-8** 1s cross RH to double triangle position with 2s+3s & set, 1s cast up to top & dance down until they are between 2s & 3s
- 9-16** 1L dances RH across with 2M+3M **while** 1M dances LH across with 2L+3L, 1s followed by 2s+3s dance down centre
- 17-24** 3s followed by 2s+1s dance up & 3s+2s cast down to places, 1L dances LH across with 2M+3M **while** 1M dances RH across with 2L+3L
- 25-32** 1s dance up to top & cast down to 2nd place opposite side, 1s dance 1/2 Fig of 8 around 2s to end in 2nd place on own sides

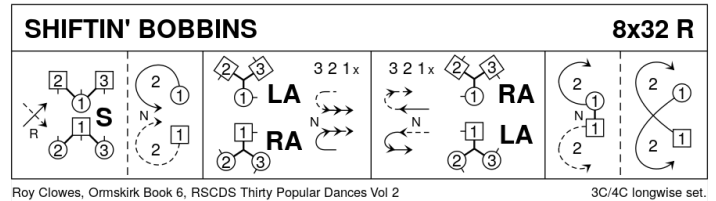

11 DAVID RUSSELL HALL R40 · 3/4L

Ken Whittle: *RSCDS XLII 9* · Crib: *MiniCribs* · Diagram: *Keith Rose's Diagrams*

- 1-8** 1s cross RH, cast 1 place, dance down between 3s & cast up to join LH with partner & RH with 2nd corners
- 9-16** 1s+2nd corners Bal-in-Line, face corners & set, turn corners RH & pass partner LSh to face 3rd corner (pstn) **while** 1st corners set turning left to dance clockwise 1/2 way to change places & set
- 17-20** 1s dance 1/2 diagonal RSh reel of 4 with corners to join LH with partner & RH with 1st corners (pstn)
- 21-28** 1s+1st corners Bal-in-Line, face corners & set, turn corners RH & pass partner LSh to face 2nd corner (pstn) **while** 2nd corners set turning left to dance clockwise 1/2 way to change places & set
- 29-32** 1s dance 1/2 diagonal reel with corners, give LH briefly to end LSh/LSh
- 33-40** 1s dance RH across (1L with 2s & 1M with 3s), pass RSh & dance LH across with other couple to end 2nd place own side

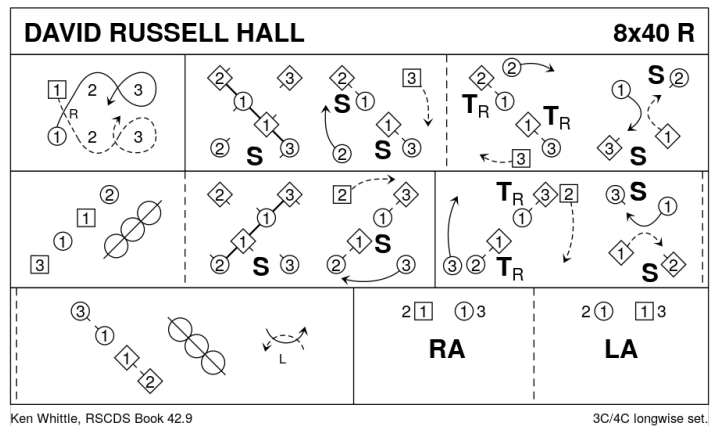

12 THE BLUE MESS JACKET S32 · 4/4L

Douglas Henderson: Kinclaven Pocket Book of Six Scottish Country Dances · Crib: MiniCribS · Diagram: Keith Rose's Diagrams

- 1-8** 2s followed by 1s lead down the middle, 1s cross & cast up to top & curve in to end BtoB facing 2s who have danced back to place
- 9-16** 'The Spurtle':
9-12 1s dance 1/2 RSh reel of 4 with 2s & turn RH to face 3s (M facing L)
13-16 Repeat with 3s but end facing 4s
17-20 Repeat with 4s
21-24 1s continue turn to end in 4th place opposite sides & all set (2) (3) (4) (1)
- 25-32** All Petronella to centre & set, Petronella to own sides & set. 2 3 4 1

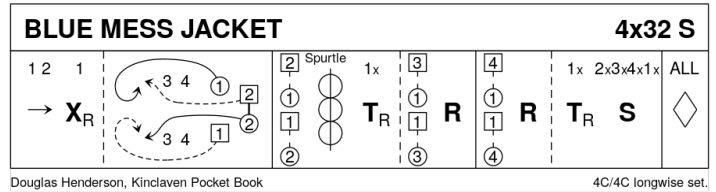

13 STAIRCASE IN STYRIA R40 · 5/5L

Margaret Gray: CD booklet of The Sunday Class Dance Book 2 · Crib: MiniCribS · Diagram: Keith Rose's Diagrams

- 1-8** 1s+2M also 3s+4M dance RH across, 1s+2L also 3s+4L dance LH across
- 9-16** 1s+4M also 3s+5M dance RH across, 1s+4L also 3s+5L dance LH across & 1L also 3L end facing out Ladies side with partners behind them
- 17-24** 1s & 3s dance out Ladies' side & cast up 1 place, cross to Mens side & cast up to original place Ladies looping round by the right
- 25-32** 1s cross & cast 1 place, 1s followed by 3s dance up & cast (1s to 3rd place, 3s to 2nd place)
- 33-40** 1s cross & cast 1 place, 1s followed by 5s dance up & cast (1s to 5th place, 5s to 4th place). 2 3 4 5 1
- NB - No stepping up or down until bar 27

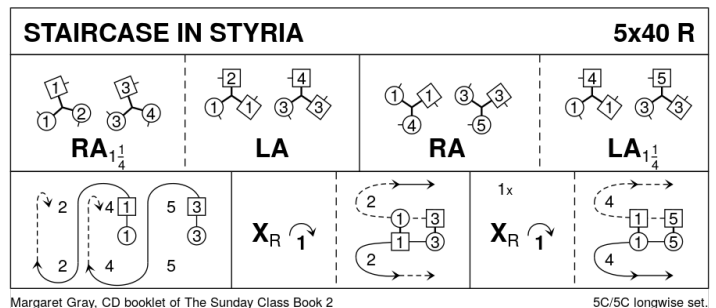

14 JIM'S HABERDASHERY J40 · 3/4L

Alan Macpherson: Bannockburn 700 · Crib: MiniCribS · Diagram: Keith Rose's Diagrams

- 1-8** 1s+2s dance Double Fig of 8 (1s crossing down)
- 9-16** 1M+2M turn RH & 1L+2L turn LH 1.1/2 times (4 bars), 1s dance out own side, down behind 3s & cross up to 2nd place opposite sides
- 17-24** 1s dance reels of 3 on opposite sides (1s out & up/2s in & down to start), 1s end crossing up to 2nd place own sides
- 25-32** 1s dance reels of 3 on own sides (1s out & up to start), 1s end in centre facing up
- 33-40** 1s dance up to top, cast to 2nd place & 2s+1s+3s turn RH

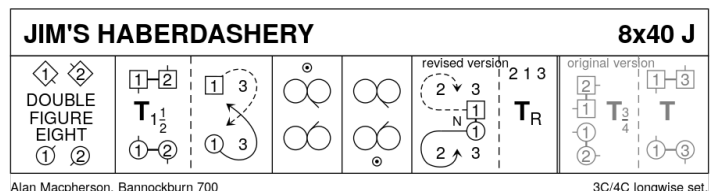

Original version: - 33-40 1s turn 2s with nearer hand (4 bars) & turn 3s with other hand (4 bars)

15 FRIENDSHIPS S32 · 4/4L

Jennie Miller: A Third Book of Graded Scottish Country Dances · Crib: MiniCribbs · Diagram: Keith Rose's Diagrams

- 1-8** 1s+3s dance down between 2s/4s and cast back to places, 1s+2s also 3s+4s dance circle 4H round to Left
- 9-16** 2s+4s dance up between 1s/3s and cast back to places. 1s+2s also 3s+4s dance circle 4H round to Right
- 17-24** 1s+2s set, 1/2 RH across. 1s+3s set, 1/2 LH across
- 25-32** 1s+4s set, 1/2 RH across. All 4 couples set and cross RH

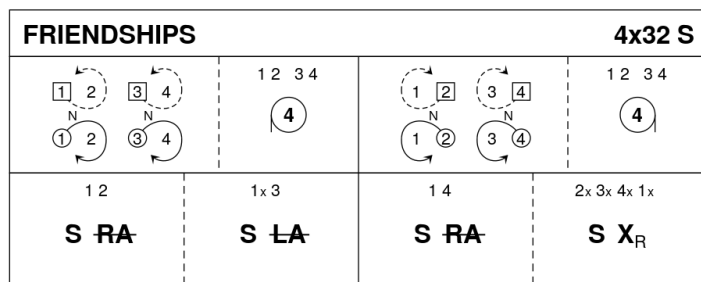

Jennie Miller, RSCDS Graded Book 3.3

4C/4C longwise set.

16 THE DANCING BEES R32 · 3/4L

Roy Goldring: Graded and Social Dances 1 - 24 Dances · Crib: MiniCribbs · Diagram: Keith Rose's Diagrams

- 1-8** 1s lead down the middle & back to face 2L in prom hold
- 9-16** 1s dance reel of 3 across with 2s (giving RSh to 2L)
- 17-24** 1s dance reel of 3 across with 3s (LSh to 3L) ending in the middle (Man facing down & Lady facing up to partner)
- 25-32** 1s set in middle, petronella to 2nd place own sides & 2s+1s+3s turn RH (4 bars)

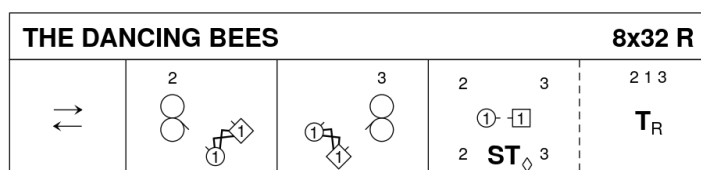

Roy Goldring, 24 Graded & Social Dances

3C/4C longwise set.

17 BLEATHERING BETH J32 · 3/4L

Garry Robertson: 90 - Twelve anniversary dances celebrating ninety years of RSCDS Edinburgh Branch 1 · Crib: MiniCribbs · Diagram: Keith Rose's Diagrams

- 1-8** 1L followed by 1M casts 1 place, dances across to 2nd place opp. sides (2s step up 3-4). 1L+2M also 1M+2L turn RH
- 9-16** 1L followed by 1M casts down 1 place, dances across to 3rd place own sides (3s step up 11-12). 1M+3M also 1L+3L turn LH
- 17-24** 1s set, dance up middle, finish back to back facing own sides 2nd place (3s step down 19-20) 2s+1s+3s dance 4 bars Double Triangles
- 25-32** 1L casts up round 2M, thru 2s as 1M casts down round 3L, thru 3s to 2nd place own sides. 2s+1s+3s turn RH (1L remains facing out to repeat)

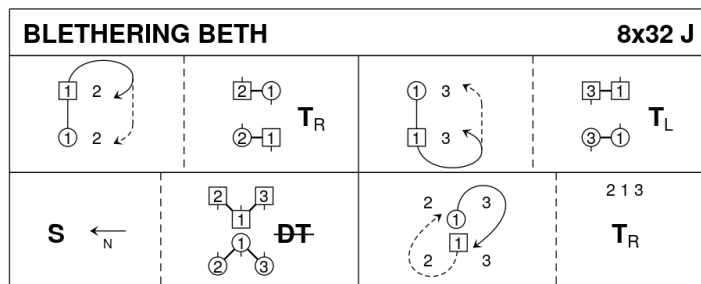

Garry Robertson, 2012, Edinburgh 90th Anniversary

3C/4C longwise set.

18 THE ORCHARDS OF CO. ARMAGH

S32 · 3/3L

Jinty Anderson: Belfast Branch Platinum Anniversary Dances · Crib: MiniCribbs · Diagram: Keith Rose's Diagrams

- 1-8** 1M leading 2M+3M also 3L leading 2L+1L chase clockwise 1/2 round to opp sides (4 bars). All set, 1s+3s turn partners 3/4 RH into line up/down (Men facing down)
- 9-12** 3s+1s dance 1/2 reel of 4, 1M+3L pass LSH to face 2s (1M+2M & 3L+2L facing), 1L+3M remain in centre at top/bottom
- 13-16** 1M+3L+2s dance 1/2 reel of 4 across, 1M & 3L pass LSh to face partners up/down set
- 17-24** 1s+3s dance 1/2 reel of 4, 1M+3L pass LSh to face own partners. 3s+1s set, petronella turn to own sides. 3 2 1
- 25-32** 2s followed by 1s dance up to top, cast, 2s to 3rd place, 1s to 2nd place (4 bars). 3s+1s+2s turn partners 2H

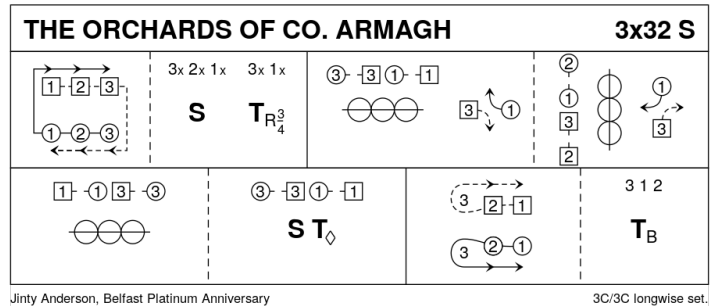

19 THE FLIGHT OF THE FALCON

J32 · 3/4L

Barry Priddey: Anniversary Tensome · Crib: MiniCribbs · Diagram: Keith Rose's Diagrams

- 1-8** 1s set, cast 1 place & turn LH to 1M facing his 1st corner with his partner behind him
- 9-16** 1M followed by partner dance a full RSh diagonal Alternating Tandem reel of 3 with 1st corners & end facing Ladies 2nd corner
- 17-24** 1M followed by partner dance a RSh Alternating Tandem reel of 3 with 2nd corners & 1s end facing own 1st corners
- 25-32** 1s turn 1st corners RH, pass RSh, turn 2nd corner RH & pass RSh to 2nd place own sides (corners turn for 4 bars)

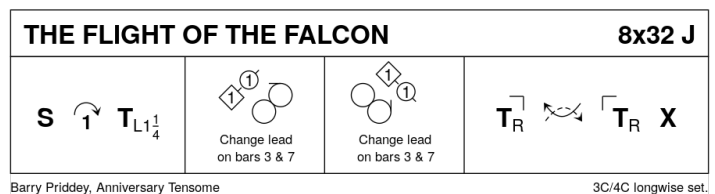

20 A TOUCH OF TARTAN

R32 · 3/4L

Irene van Maarseveen: The Dancing Thistles · Crib: MiniCribbs · Diagram: Keith Rose's Diagrams

- 1-8** 1s turn RH, cast 1 place (2s step up) & turn 1.1/4 LH to face 1st corners
- 9-16** 1s dance DoSiDo with 1st corners, turn 1st corners RH & pass partner LSh to face 2nd corners
- 17-24** 1s dance DoSiDo with 2nd corners, turn 2nd corners RH & pass partner RSh to 2nd places
- 25-32** 2s+1s+3s circle 6H round & back

